

**2011 Formula SAE® Rules
Table of Contents**

INTRODUCTION 3

PART A – ADMINISTRATIVE REGULATIONS 6

ARTICLE 1: FORMULA SAE OVERVIEW AND COMPETITION 6

ARTICLE 2: THE 2011 FORMULA SAE SERIES 7

ARTICLE 3: FORMULA SAE RULES AND ORGANIZER AUTHORITY 8

ARTICLE 4: INDIVIDUAL PARTICIPATION REQUIREMENTS 10

ARTICLE 5: FACULTY ADVISOR 11

ARTICLE 6: VEHICLE ELGIBILITY 12

ARTICLE 7: REGISTRATION 13

ARTICLE 8: VEHICLE DOCUMENTATION, DEADLINES AND PENALTIES 15

ARTICLE 9: PROTESTS 16

ARTICLE 10: QUESTIONS ABOUT THE FORMULA SAE RULES 17

APPENDIX S: SAE TECHNICAL STANDARDS 19

PART B – TECHNICAL REQUIREMENTS 22

ARTICLE 1: VEHICLE REQUIREMENTS & RESTRICTIONS 22

ARTICLE 2: GENERAL DESIGN REQUIREMENTS 22

ARTICLE 3: DRIVER’S CELL 23

ARTICLE 4: COCKPIT 37

ARTICLE 5: DRIVERS EQUIPMENT (BELTS AND COCKPIT PADDING) 39

ARTICLE 6: GENERAL CHASSIS RULES 43

ARTICLE 7: BRAKE SYSTEM 45

ARTICLE 8: POWERTRAIN 46

ARTICLE 9: FUEL AND FUEL SYSTEM 51

ARTICLE 10: EXHAUST SYSTEM AND NOISE CONTROL 53

ARTICLE 11: ELECTRICAL SYSTEM 54

ARTICLE 12: AERODYNAMIC DEVICES 56

ARTICLE 13: COMPRESSED GAS SYSTEMS AND HIGH PRESSURE HYDRAULICS 56

ARTICLE 14: FASTENERS 57

ARTICLE 15: TRANSPONDERS 57

ARTICLE 16: VEHICLE IDENTIFICATION 58

ARTICLE 17: EQUIPMENT REQUIREMENTS 59

ARTICLE 18: POSSIBLE FUTURE RULES CHANGES 63

TECHNICAL DRAWINGS 65

APPENDIX AF: ALTERNATIVE FRAME RULES 66

APPENDIX B-1: 2011 FSAE™ STRUCTURAL EQUIVALENCY FORM – Page 1 of 2 72

APPENDIX B-1: 2011 FSAE™ STRUCTURAL EQUIVALENCY FORM Page 2 of 2 73

APPENDIX B-2: 2011 FSAE™ IMPACT ATTENUATOR DATA REPORT – Page 1 of 3 74

APPENDIX B-2: 2011 FSAE™ IMPACT ATTENUATOR DATA REPORT – Page 2 of 3 75

APPENDIX B-2: 2011 FSAE™ IMPACT ATTENUATOR DATA REPORT – Page 3 of 3 76

PART C – STATIC EVENT REGULATIONS 77

ARTICLE 1: STATIC EVENTS AND MAXIMUM SCORES..... 77

ARTICLE 2: TECHNICAL INSPECTION 77

ARTICLE 3: COST AND MANUFACTURING EVENT 79

ARTICLE 4: PRESENTATION EVENT 90

ARTICLE 5: DESIGN EVENT..... 92

APPENDIX C – 1: COST MODELS AND COST METHODOLOGY 97

APPENDIX C – 2: STANDARD PART NUMBERING..... 97

APPENDIX C – 3: ORGANIZED LIST OF SYSTEMS & ASSEMBLIES 97

APPENDIX C – 4: POWER TOOL PACKAGE ENVELOPES 97

APPENDIX C – 5: 2011 FSAE COST EVENT ADDENDUM 98

APPENDIX C – 6: PRESENTATION JUDGING..... 99

APPENDIX C – 7: DESIGN JUDGING SCORE SHEET 100

PART D – DYNAMIC EVENT REGULATIONS 101

ARTICLE 1: DYNAMIC EVENTS AND MAXIMUM SCORES 101

ARTICLE 2: WEATHER CONDITIONS 101

ARTICLE 3: RUNNING IN RAIN..... 101

ARTICLE 4: DRIVER LIMITATIONS..... 103

ARTICLE 5: ACCELERATION EVENT..... 104

ARTICLE 6: SKID-PAD EVENT..... 105

ARTICLE 7: AUTOCROSS EVENT 108

ARTICLE 8: ENDURANCE AND FUEL ECONOMY..... 110

ARTICLE 9: FLAGS..... 117

ARTICLE 10: RULES OF CONDUCT 118

ARTICLE 11: GENERAL RULES 119

ARTICLE 13: PIT RULES..... 120

ARTICLE 14: DRIVING RULES..... 120

ARTICLE 15: DEFINITIONS 121

2011 Formula SAE Rules

INTRODUCTION

This introduction highlights some areas of the 2011 Formula SAE Rules that you may find of interest. These highlights touch on only part of the revised text and do not replace or change the Rules.

Caution - Neither this introduction, nor any other summary, is a substitute for reading and understanding the Rules. The Rules are a reference document and should be used for that purpose. Do not attempt to design your car based on the parts of the Rules you happen to remember from the last time you read them. We cannot stress it too strongly – read the Rules thoroughly and repeatedly.

AF Alternate Frame Rules – Appendix AF – New Options in Frame Design

The Rules Committee has introduced a set of alternate frame rules (AF Rules) that will allow teams a wider range of options in the design and fabrication of your car. The AF Rules do not change the essential structural requirements, but will give you a different approach to proving compliance. When the AF Rules are used some, but not all, of the rules in Part B are suspended.

We urge you to review the Alternate Frame Rules and decide if they are the right approach for your team. If you elect to use these rules for 2011 you must notify the Rules Committee of your intent by November 1, 2010.

While the AF Rules open new directions in frame design, for the near future they'll be a work in progress. As they're used questions will arise and new interpretations and clarifications will be issued. The Rules Committee will work closely with any team using the AF Rules. Rules questions, answers and clarifications will be shared with all teams. We encourage teams to work with the Committee to refine these AF Rules

AF2 Structural Requirements Compliance Form (SRCF) – Alternate Frame Rules Document

Teams using the AF Alternate Frame Rules are required to submit a Structural Requirements Compliance Form (SRCF) for review by the Committee.

The SRCF replaces the Structural Equivalency Form (SEF) for cars built to the AF Rules.

A8 - Vehicle Documents, Deadlines and Penalties – Summary Provided

Late penalties for document submissions, where penalties apply, have been standardized at ten (-10) points per day. However each event differs in the consequences not submitting a required document.

To clarify the submission requirements we've collected them together as Article A8 which summarizes, but doesn't supersede, the individual event rules. Hopefully you'll get all your documents in on time and won't have to worry about penalties.

B3.4.2 Alternate Tubing and Materials – Restriction on Welded Magnesium

The use of "... magnesium on which welding has been utilized" is prohibited in the Primary Structure. Magnesium may continue to be used for most other applications.

B3.9.4 Relating to “Percy” – Measurement Position Clarified

The positioning method for the 95th percentile male template has been clarified.

B3.21 Impact Attenuator Data Requirement – Revised Test Requirements & Standard Design

The impact attenuator test requirements have been revised. The Impact Attenuator Data form, Appendix B-2, has been expanded to include a graph of your energy displacement curve, a plan of your attenuator and before and after photographs.

Additionally the Committee has decided to develop, test and release a **standard attenuator design**. The standard design will be an option to a unique team designed attenuator. Development and testing of the standard attenuator is currently underway and should be completed within the next few months. The design will then be published on the FSAE website. If you chose to employ the standard attenuator design, then testing is not required and there is no need to submit test data specific to your car. The Impact Attenuator Form must still be submitted as is proof your design matches the standard design.

B3.21.10 – Dynamic Tests – Restrictions on Do-it-Yourself Tests

Dynamic tests on impact attenuators may only be done using university owned equipment or equipment at a corporate or commercial test site. Creating your own test rig of any type is **prohibited** and the data from such tests will not be accepted. If you can't get access to dynamic test equipment then run a quasi-static test. In either case be careful.

B6.2 Ground Clearance – Requirement Deleted

The 25.4 mm (1 in) minimum ground clearance requirement has been deleted. However, teams are reminded that D1.1.2 prohibits vehicle conditions that might compromise the track surface. Vehicle contact that could damage the timing wires or the track is cause for disqualification.

B7.1 Brake System – Pedal Strength Requirement

A minimum pedal strength requirement has been added. Pedals must be fabricated from either steel or aluminum or machined from aluminum, steel or titanium.

B8.1.1 Engine Limitation – Waste Engine Heat Recovery Allowed

Team may, at their option, recover and use waste/rejected heat from the engine.

B9.7 Tank Filling Requirement

B9.7.1 The fuel tank must be capable of being filled to capacity without manipulating the tank or the vehicle in any way. During fueling, or refueling, the vehicle may only be touched by the fuel crew and officials. The tank will be filled to the fuel fill line, or if a filling system is being used, to the automatic stop point. If the fuel level changes after the team has moved the vehicle, no additional fuel will be added.

B12 Aerodynamic Devices – Minimum Radius Reduced & Locations Liberalized

The minimum radius for most aerodynamic devices of any description or location has been standardized to 1.5 mm (0.060 in).

Aerodynamic devices may now extend, with limits, forward and behind the tires.

B17.1 Drivers Equipment – Fire Resistance Requirements Increased

Starting with the 2011 competition season drivers will be required to wear one piece, two layer fire resistant suits with non-synthetic material underwear. (Before you ask, we're not going to be the underwear police. We'll trust what you tell us about what you're wearing.) Various other drivers gear requirements have been revised to further define the required fire protection. Be sure to check your gear to be certain it complies with the rules before you arrive at the competition.

B3.26ff Monocoque Requirements - Clarifications

The consolidated monocoque rules, B26ff, have been clarified especially in the requirements for attachment points. A section on Driver's Harness Attachment Points has been added.

C5.7 – Student Activity Disclosure– Required Document

Teams are required to submit a statement of the level of team activity involved in designing, fabricating and assembling all major components of the car. A simple, one page "Student Activity Disclosure Form" form with check boxes will be found under "Rules and Important Documents" on the FSAE website. Late penalties apply for non-submission but no other points will be awarded for any answers given on the form. This is a data gathering exercise for the organizers.

D8.19 Endurance Scoring Formula – Minimum Score Revised

The scoring formula for Endurance has been revised to set the minimum number of points a team will earn equal to the number of laps completed. This change will give a small number of points to teams that do not complete the event and will recognize that they competed. As an example, a team that fails to restart after driver change at FSAE Michigan will now earn an Endurance score of 11 points for having completed 11 laps.

2011 Formula SAE Rules

PART A – ADMINISTRATIVE REGULATIONS

ARTICLE 1: FORMULA SAE OVERVIEW AND COMPETITION

A1.1 Formula SAE Competition Objective

The Formula SAE® Series competitions challenge teams of university undergraduate and graduate students to conceive, design, fabricate and compete with small, formula style, vehicles.

A1.1.1 To give teams the maximum design flexibility and the freedom to express their creativity and imaginations there are very few restrictions on the overall vehicle design. The challenge to teams is to develop a vehicle that can successfully compete in all the events described in the FSAE Rules. The competitions themselves give teams the chance to demonstrate and prove both their creativity and their engineering skills in comparison to teams from other universities around the world.

A1.2 Vehicle Design Objectives

For the purpose of the Formula SAE competition, teams are to assume that they work for a design firm that is designing, fabricating, testing and demonstrating a prototype vehicle for the non-professional, weekend, competition market.

A1.2.1 The vehicle should have very high performance in terms of acceleration, braking and handling and be sufficiently durable to successfully complete all the events described in the Formula SAE Rules and held at the Formula SAE competitions.

A1.2.2 The vehicle must accommodate drivers whose stature ranges from 5th percentile female to 95th percentile male and must satisfy the requirements of the Formula SAE Rules.

A1.2.3 Additional design factors to be considered include: aesthetics, cost, ergonomics, maintainability, manufacturability, and reliability.

A1.2.4 Once the vehicle has been completed and tested, your design firm will attempt to “sell” the design to a “corporation” that is considering the production of a competition vehicle. The challenge to the design team is to develop a prototype car that best meets the FSAE vehicle design goals and which can be profitably marketed.

A1.2.5 Each design will be judged and evaluated against other competing designs to determine the best overall car.

A1.3 Good Engineering Practices

Vehicles entered into Formula SAE competitions are expected to be designed and fabricated in accordance with good engineering practices.

A1.4 Judging Categories

The cars are judged in a series of static and dynamic events including: technical inspection, cost, presentation, and engineering design, solo performance trials, and high performance track endurance.

A1.4.1 The dynamic events are scored to determine how well the car performs. Each dynamic event has specified minimum acceptable performance levels that are reflected in the scoring equations.

The following points are possible:

Static Events:

Presentation	75
Engineering Design	150
Cost Analysis	100

Dynamic Events

Acceleration	75
Skid-Pad	50
Autocross	150
Fuel Economy	100
<u>Endurance</u>	<u>300</u>

Total Points 1,000

ARTICLE 2: THE 2011 FORMULA SAE SERIES

A2.1 The 2011 Formula SAE Competition Series consists of the following seven (7) competitions:

1. Formula SAE Michigan held in Michigan, USA and organized by SAE International.
2. Formula SAE California held in California, USA and organized by SAE International.
3. Formula SAE Australasia held in Australia and organized by SAE Australasia
4. Formula SAE Brazil held in Brazil and organized by SAE Brazil
5. Formula SAE Italy held in Italy and organized by ATA
6. Formula Student held in the United Kingdom and organized by IMechE
7. Formula Student Germany held in Germany and organized by VDI.

A2.2 Open Registration

All Formula SAE competitions have open registration policies and accept registrations by student teams representing universities in any country.

A2.3 Rule Variations

All competitions in the Formula SAE Series may post some minor rule variations specific to the operation of the events in their countries. However, the vehicle design requirements and restrictions will remain unchanged. Any rule variations will be posted on the websites specific to those competitions.

A2.4 Official Announcements and Competition Information

Teams are required to read the published announcements by SAE and the other organizing bodies and to be familiar with all official announcements concerning the competitions and rules interpretations released by the FSAE Rules Committee.

A2.4.1 Formula SAE news is published online and can be found at:

<http://students.sae.org/competitions/formulaseries/>

A2.5 Official Languages

The official language of the Formula SAE series is English. Document submissions, presentations and discussions in English are acceptable at all competitions in the series.

A2.5.1 Team members, judges, and officials at FSAE Brazil, FSAE Italy and Formula Student Germany may use their respective national languages for document submissions, presentations and discussions if all the parties involved agree to the use of that language.

A2.5.2 The languages in use at the competitions of Formula SAE series are:

- Formula SAE Michigan - English
- Formula SAE California - English
- Formula SAE Australasia - English
- Formula SAE Brazil - Portuguese and English
- Formula SAE Italy - Italian and English
- Formula Student – English
- Formula Student Germany – German and English

A2.6 Competition Codes

The competition codes that must be used as part of the file names of the various documents and data that are required to be submitted electronically are:

- Formula SAE Michigan - FSAEM
- Formula SAE California - FSAEC
- Formula SAE Australasia - FSAEA
- Formula SAE Brazil - FSAEB
- Formula SAE Italy - FSAEI
- Formula Student – FS
- Formula Student Germany - FSG

ARTICLE 3: FORMULA SAE RULES AND ORGANIZER AUTHORITY

A3.1 Rules Authority

The Formula SAE Rules are the responsibility of the Formula SAE Rules Committee and are issued under the authority of the SAE University Programs Committee.

A3.1.1 Official announcements from the Formula SAE Rules Committee, SAE or the other Formula SAE organizing bodies shall be considered part of, and shall have the same validity as, these rules.

A3.1.2 Ambiguities or questions concerning the meaning or intent of these rules will be resolved by the Formula SAE Rules Committee, SAE or by the individual competition organizers as appropriate.

A3.2 Rules Validity

The Formula SAE Rules posted on the SAE website and dated for the calendar year of the competition are the rules in effect for the competition.

A3.2.1 Rule sets dated for other years are invalid.

A3.3 Rules Compliance

By entering a Formula SAE competition the team, members of the team as individuals, faculty advisors and other personnel of the entering university agree to comply with, and be bound by, these rules and all rule interpretations or procedures issued or announced by SAE, the Formula SAE Rules Committee and the other organizing bodies.

- A3.3.1 *Any rules or regulations pertaining to the use of the competition site by teams or individuals and which are posted, announced and/or otherwise publically available are incorporated into the FSAE Rules by reference. As examples, all event site waiver requirements, speed limits, parking and facility use rules apply to FSAE participants.*
- A3.3.2 All team members, faculty advisors and other university representatives are required to cooperate with, and follow all instructions from, competition organizers, officials and judges.
- A3.4 Understanding the Rules**
Teams, team members as individuals and faculty advisors, are responsible for reading and understanding the rules in effect for the competition in which they are participating.
- A3.5 Participating in the Competition**
Teams, team members as individuals, faculty advisors and other representatives of a registered university who are present on-site at a competition are considered to be “participating in the competition” from the time they arrive at the event site until they depart the site at the conclusion of the competition or earlier by withdrawing.
- A3.6 Violations on Intent**
The violation of intent of a rule will be considered a violation of the rule itself.
- A3.6.1 Questions about the intent or meaning of a rule may be addressed to the Formula SAE Rules Committee or by the individual competition organizers as appropriate.
(See Article A10)
- A3.7 Right to Impound**
SAE and other competition organizing bodies reserve the right to impound any onsite registered vehicles at any time during a competition for inspection and examination by the organizers, officials and technical inspectors.
- A3.8 Restriction on Vehicle Use**
Teams are cautioned that the vehicles designed in compliance with these Formula SAE Rules are intended for competition operation only at the official Formula SAE competitions.
- A3.9 Headings**
The article, section and paragraph headings in these rules are provided only to facilitate reading: they do not affect the paragraph contents.
- A3.10 General Authority**
SAE and the competition organizing bodies reserve the right to revise the schedule of any competition and/or interpret or modify the competition rules at any time and in any manner that is, in their sole judgment, required for the efficient operation of the event or the Formula SAE series as a whole.
- A3.11 SAE Technical Standards Access**
A cooperative program of SAE’s Education Board and Technical Standards Board is making some of SAE’s Technical Standards available to teams registered for any North American CDS competition at no cost. The Technical Standards referenced in the Collegiate Design Series rules, along with other standards with reference value, will be accessible online to registered teams, team members and faculty advisors. To access the standards (1) your team must be registered for a competition in North America and (2) the individual team member or faculty advisor wanting access must be linked to the team in SAE’s system.

Access Procedure - Once your team has registered there will be a link to the technical standards titled “Design Standards” on the main registration screen where all the required onsite insurance information is added. On the technical standards webpage you will have the ability to search standards either by J-number assigned or a topic of interest such as brake light.

A list of accessible SAE Technical Standards can be found in Appendix S.

ARTICLE 4: INDIVIDUAL PARTICIPATION REQUIREMENTS

A4.1 Eligibility Limits

Eligibility is limited to undergraduate and graduate students to insure that this is an engineering design competition.

A4.2 Student Status

Team members must be enrolled as degree seeking undergraduate or graduate students in a college or university. Team members who have graduated during the seven (7) month period prior to the competition remain eligible to participate.

A4.3 Society Membership

Team members must be members of at least one of the following societies: (1) SAE International, (2) SAE Australasia, (3) SAE Brazil, (4) ATA, (5) IMechE or (6) VDI. Proof of membership, such as membership card, is required at the competition.

Note: Students can join SAE online at: www.sae.org/students

A4.4 Age

Team members must be at least eighteen (18) years of age.

A4.5 Driver’s License

Team members who will drive a competition vehicle at any time during a competition must hold a valid, government issued driver’s license.

A4.6 Liability Waiver

All on-site participants, including students, faculty and volunteers, are required to sign a liability waiver upon registering on-site.

A4.7 Medical Insurance

Individual medical insurance coverage is required and is the sole responsibility of the participant.

A4.8 Individual Registration Requirements for North American Competitions – ACTION REQUIRED

A4.8.1 All students and faculty, both domestic and international, if you have an SAE International membership, make sure you are affiliated to your respective school/ college/ university on the SAE website under your “MySAE”.

A4.8.2 If you are not a member of SAE International or other approved societies, you will need to join SAE International online at www.sae.org. Select the “Join SAE / Membership Renewal” link under “Quicklinks”, and then select the “Join SAE” link under “Join SAE International”. Students will need to select the “Student Membership” link and then follow the series of the questions that are asked. Faculty that wishes to be SAE members should choose the “Professional Membership” link and

proceed to the series of questions. Please note all student participants must be SAE International members to participate in the event. It is not mandatory for faculty to join.

- A4.8.3 All international student participants (or unaffiliated faculty advisors) who are not SAE International members are required to complete the International Student Registration form for the entire team found in the specific event registration webpage. Upon completion, email the form to CollegiateCompetitions@sae.org stating which event and university name.
- A4.8.4 **Online registration information is required!** Every participant, including advisors must affiliate themselves and complete the following information on under the team's registration page on the SAE website:
- Medical insurance (provider, policy/ID number, telephone number)
 - Driver's license (state/country, ID number)
 - Emergency contact data (point of contact (parent/guardian, spouse), relationship, and phone number)

To do this you will need to go to "Registration" page under the specific event the team is registered and then click on the "Register Your Team / Update Team Information" link. At this point, if you are properly affiliated to the school/college/university, a link will appear with your team name to select. Once you have selected the link, the registration page will appear. Selecting the "Add New Member" button will allow individuals to include themselves with the rest of the team. This can also be completed by team captain and faculty advisor for all team members.

PLEASE BRING YOUR OFFICIAL DRIVER'S LICENSE OR PASSPORT TO ONSITE REGISTRATION. ALSO PLEASE BRING YOUR MEDICAL INSURANCE CARD.

All students, both domestic and international, must affiliate themselves online or submit the International Student Registration form by **March 1, 2011**. For additional assistance, please contact CollegiateCompetitions@sae.org.

ARTICLE 5: FACULTY ADVISOR

A5.1 Status

Each team is expected to have a Faculty Advisor appointed by the university. The Faculty Advisor is expected to accompany the team to the competition and will be considered by competition officials to be the official university representative.

A5.2 Responsibilities

Faculty Advisors may advise their teams on general engineering and engineering project management theory.

A5.3 Limitations

Faculty Advisors may not design any part of the vehicle nor directly participate in the development of any documentation or presentation.

Additionally, Faculty Advisors may not fabricate nor assemble any components nor assist in the preparation, maintenance, testing or operation of the vehicle.

In Brief – Faculty Advisors may not design, build or repair any part of the car.

ARTICLE 6: VEHICLE ELGIBILITY**A6.1 Student Developed Vehicle**

Vehicles entered into Formula SAE competitions must be conceived, designed, fabricated and maintained by the student team members without direct involvement from professional engineers, automotive engineers, racers, machinists or related professionals.

A6.2 Information Sources

The student team may use any literature or knowledge related to car design and information from professionals or from academics as long as the information is given as a discussion of alternatives with their pros and cons.

A6.3 Professional Assistance

Professionals may not make design decisions or drawings and the Faculty Advisor may be required to sign a statement of compliance with this restriction.

A6.4 Student Fabrication

It is the intent of the SAE Collegiate Design Series competitions to provide direct hands-on experience to the students. Therefore, students should perform all fabrication tasks whenever possible.

A6.5 The Formula SAE Competition Year – First Year Cars

For the purpose of defining first, second and third year cars, a competition “year” is any consecutive run of the Series, i.e. Formula SAE Michigan, Formula SAE California, Formula Student, Formula Student Germany, Formula SAE Italy, Formula SAE BRASIL, and Formula SAE Australasia held within a roughly 12 month period counting from the event in which a vehicle first competes. For example, a car that competes first in Formula SAE Australasia is classified as a “first year car” until the following year’s Formula SAE Australasia competition.

Note: Teams are reminded that their vehicles must comply with the rules in effect for each competition they enter.

A6.6 First Year Vehicles – North American Formula SAE Competitions

A6.6.1 Only first year vehicles may enter the Formula SAE Competitions in North America.

A6.6.2 To be classified as a “first year vehicle” a car must, as a minimum, have a completely new frame. Photographic or other evidence will be used to determine if the frame is new.

A6.6.3 If there is any question about whether or not the car is in fact a first year vehicle, it will be the sole responsibility of the team to produce such evidence as the organizers or judges may require.

A6.7 Second Year Vehicles – North American Formula SAE Competitions

Vehicles that have competed during any previous Formula SAE year are prohibited from Formula SAE competitions held in North America.

A6.8 First Year Vehicles: FSAE-A, FSAE-B, FSAE-I, Formula Student and Formula Student Germany

A6.8.1 To be classified as a “first year vehicle” a car must, as a minimum, have a completely new frame. Photographic or other evidence will be used to determine if the frame is new.

- A6.8.2 If there are any questions about whether or not the car is in fact a first year vehicle, it will be the sole responsibility of the team to produce such evidence as the organizers or judges may require.
- A6.9 Second Year Vehicles: FSAE-A and FSAE-B**
- A6.9.1 Vehicles that have competed during any one (1) previous Formula SAE year may compete provided that they have been substantially modified from their first appearance. Photographic and design documentation detailing the modifications are required along with a statement from the team’s Faculty Advisor.
- A6.9.2 Penalties for insufficient redesign or insufficient knowledge by the team will be applied during the Design Event. Refer to the Rule C5.15 “Penalties for Insufficient Redesign”.
- A6.10 Third Year Vehicles –Prohibited**
- A6.10.1 Vehicles that have competed in any two (2) previous Formula SAE years are prohibited from participating in any Formula SAE competition.
- A6.10.2 Any team found to have entered a vehicle that contravenes this rule will be disqualified. Additionally, the team will be required to submit such documentation as the organizers may require in advance of the acceptance of any future registration.

ARTICLE 7: REGISTRATION

- A7.1 Registration – North American Formula SAE Competitions**
Registration for Formula SAE competitions held in North America must be completed on-line. Online registration must be done by either (a) an SAE member or (b) the official faculty advisor connected with the registering university and recorded as such in the SAE record system.

Note: It typically takes at least 1 working day between the time you complete an on-line SAE membership application and our system recognizes you as eligible to register your team.

- A7.2 Entries per University – North American Formula SAE Competitions – One per Competition**
Registration for Formula SAE competitions held in North America is limited to one (1) vehicle per university per competition depending on available space.

- A7.3 Registration Limits - North American Formula SAE Competitions**
Registration for the North American Formula SAE competitions is limited as follows:

Formula SAE Michigan	120 teams
Formula SAE California	80 teams

Registration for each FSAE competitions closes as soon as the registration limit is reached. We strongly advise teams to register as soon as registration opens.

- A7.4 Registration Dates – North American Formula SAE Competitions**
Registration for the North American Formula SAE competitions will open at 10:00 am EST, Monday, October 4, 2010

For the first month of the registration period a team may enter either FSAE Michigan or FSAE California, but not both.

Specifically, from 10:00 am EST, Monday, October 4, 2010 until 10:00 am EST, Thursday, November 4, 2010, teams may register for either Formula SAE Michigan or Formula SAE California. After the first month of registration any untaken slots at any of the competitions will be available to any team on a first come, first serve basis.

Specifically from 10:00 am EST, Thursday, November 4, 2010, until the close of registration at 11:59 pm Monday, December 20, 2010 teams may register for any competition in which registration slots are available.

Registration for the North American Formula SAE competitions will close at 11:59 pm EST Monday, December 20, 2010 or when all the registration slots have been taken, whichever occurs first.

There is no late registration and there are no exceptions to this registration policy.

A7.5 Formula SAE Australia, Formula SAE Brazil, Formula SAE Italy, Formula Student and Formula Student Germany

Note: Check the individual competition websites for exact registration requirements, applicable to those events.

A7.6 Registration Fees

A7.6.1 Registration fees must be paid to the organizer by the deadline specified on the respective competition website.

A7.6.2 Registration fees are not refundable and may not be transferred to a subsequent year's competition.

A7.7 Withdrawals

A7.7.1 Registered teams that find that they will not be able to attend the competition are requested to officially withdraw by notifying the following no later than one (1) week before the event:

A7.7.2 Formula SAE North American Event withdrawals: Kaley Zundel, kzundel@sae.org

A7.7.3 For events outside North America, please visit the respective competition website for contact information.

A7.8 United States Visas

Teams requiring visas to enter to the United States are advised to apply at least sixty (60) days prior to the competition. Although most visa applications seem to go through without an unreasonable delay, occasionally teams have had difficulties and in several instances visas were not issued before the competition.

Don't wait – apply early for your visa.

Neither SAE staff nor any competition organizers are permitted to give advice on visas, customs regulations or vehicle shipping regulations concerning the United States or any other country.

A7.9 Vehicle Shipping

Vehicle shipments by commercial carrier must comply with the laws and regulations of nations from which, and to which, the car is being sent. Teams are advised to consult with their shipping company or freight forwarder to be sure their shipment fully complies with all relevant, customs, import/export and aviation shipping requirements.

Shipments must be sent with the sending team or university listed as the receiving party. Neither the competition organizers nor the competition sites can be listed as the receiving party.

Vehicle shipping procedures for the North American competitions are published on the Formula SAE website for each event and are incorporated into these Rules by reference.

A7.10 On-site Registration

All team members and faculty advisors must complete the on-site registration procedures immediately after they arrive at the competition site.

On-site registration must be completed and the credentials and/or other identification issued by the organizers properly worn before the car can be unloaded, uncrated or worked upon in any manner.

ARTICLE 8: VEHICLE DOCUMENTATION, DEADLINES AND PENALTIES

A8.1 Required Documents

The following documents supporting each vehicle must be submitted by the action deadlines posted on each competition website or otherwise published by the organizers.

*B3.8 “Structural Equivalency Form (SEF)” and Appendix B-1
or AF2 “Structural Requirements Certification Form (SRCF)”*

*Note – Teams must submit either an SEF unless using the AF Rules in which case the SEF is superseded by the SRCF. Submit **either** the SEF **or** the SRCF as required, but not both.*

B3.21 “Impact Attenuator Data Requirement”

B9.1 “Fuel” – Some competitions require a fuel type order – Check the website

C3.8 “Cost Report”

C5.2 “Design Report”

C5.4 “Design Spec Sheet”

C5.7 “Student Activity Disclosure Form” – The form is on the FSAE website.

Program Submissions

A8.2 Deadlines

Volunteer judges evaluate all the required submissions and it is essential that they have enough time to complete their work. There are no exceptions to the document submission deadlines and late submissions will incur penalties. Please note that different documents or submissions may have different deadlines – check the event websites.

A8.3 Submission Addresses and Formats

The addresses to which the various submissions should be sent are published on the event website or otherwise released by the organizers. Most of the required documents must be submitted by email and

in the format specified in the individual event rules or using a prescribed form. Failure to submit a document in the proper format or with an incorrect file name will be considered as “Not Submitted.” Read the event rules carefully.

A8.4 Late Submission Penalties

Documents received after the deadline will be penalized ten (10) points per day, or partial day, late with the following penalty caps and exclusions:

B3.8.5 “Structural Equivalency Form (SEF)” or AF2 “Structural Requirements Certification Form (SRCF)” – The penalty for late SEF/SRCF submission is capped at negative fifty (-50) points.

However, teams are advised that SEF/SRCF forms are evaluated in the order in which they are received and that late submissions will be reviewed last. Late SEF/SRCF approval could delay the completion of your vehicle. We strongly recommend you submit your SEF/SRCF as early as possible.

B3.21.7 “Impact Attenuator Report Penalties” - The penalty for late Impact Attenuator Report submissions is capped at negative fifty (-50) points.

B9.1 “Fuel” – There is no point penalty for late submission of a fuel type order, however once the deadline has passed your team will be allocated the basic fuel type.

Rule C3.15 “Late Submission of Cost Report” – For the first 15 days after the deadline submission penalties for late Cost Reports are capped at negative eighty (-80) points. After the first 15 days a late Cost Report is classified as “Not Submitted”. Cost Reports that are not submitted will receive negative one hundred (-100) points and may not participate in the Cost Event.

Rule C5.8 “Penalty for Late Submission or Non-submission” – The Design Report, Design Spec Sheet and Student Activity Disclosure form collectively constitute the “Design Documents”. Late submission or failure to submit all, or any one, of the Design Documents will be penalized at the standard ten (-10) points per day to a maximum of negative one hundred (-100) points. If your Design Documents are received more than ten (10) days late they will be classified as “Not Submitted” and your team will not participate in the Design Event and will receive zero (0) points for design.

Program Submissions – Program submission requirements differ across competitions and may or may not involve penalties. Please submit program material by the published deadlines.

This rule is only a summary; it does not supersede the individual event rules. Read the individual rules for complete document submission requirements. Check the competition websites for deadlines, submission addresses and other details. If you have any questions – ask us.

ARTICLE 9: PROTESTS

A9.1. It is recognized that thousands of hours of work have gone into fielding a vehicle and that teams are entitled to all the points they can earned. We also recognize that there can be differences in the interpretation of rules, the application of penalties and the understanding of procedures. The officials and SAE staff will make every effort to fully review all questions and resolve problems and discrepancies quickly and equitably

A9.2 Preliminary Review – Required

If a team has a question about scoring, judging, policies or any official action it must be brought to the organizer's or SAE staff's attention for an informal preliminary review before a protest can be filed.

A9.3 Cause for Protest

A team may protest any rule interpretation, score or official action (unless specifically excluded from protest) which they feel has caused some actual, non-trivial, harm to their team, or has had a substantive effect on their score. Teams may not protest rule interpretations or actions that have not caused them any substantive damage.

A9.4 Protest Format and Forfeit

All protests must be filed in writing and presented to the organizer or SAE staff by the team captain. In order to have a protest considered, a team must post a twenty-five (25) point protest bond which will be forfeited if their protest is rejected.

A9.6 Protest Period

Protests concerning any aspect of the competition must be filed within one-half hour (30 minutes) of the posting of the scores of the event to which the protest relates.

A9.7 Decision

The decision of the competition protest committee regarding any protest is final.

ARTICLE 10: QUESTIONS ABOUT THE FORMULA SAE RULES**A10.1 Question Publication**

By submitting a question to the FSAE Rules Committee or the competition's organizing body you and your team agree that both your question and the official answer can be reproduced and distributed by SAE, in both complete and edited versions, in any medium or format anywhere in the world.

A10.2 Question Types

The Committee will answer questions that are not already answered in the rules or FAQs or that require new or novel rule interpretations. The Committee will not respond to questions that are already answered in the rules. For example, if a rule specifies a minimum dimension for a part the Committee will not answer questions asking if a smaller dimension can be used.

A10.3 Question Submission

An electronic question submission system is being developed for the North American competitions. Until that system is ready for use questions should be submitted following the traditional procedure covered by rules A10.5 through A10.7

When the electronic submission system is ready for use an announcement will be made on the FSAE news page. Please watch for announcements.

Throughout the 2011 FSAE competition season questions can still be submitted by the traditional submission procedure found in Rules A10.3 through A10.7. However, once the electronic submission system becomes operational the Committee may choose to respond using that system.

A10.4 Frequently Asked Questions

Before submitting a question, check the Frequently Asked Questions section of the Formula SAE Forum website.

A10.5 Question Format

- A10.5.1 All rules questions must include (1) the full name and email address of the student submitting the question, (2) the name of the university – no abbreviations, (3) the number of the applicable rule and (4) *the specific competition your team has, or is planning to, enter.*
- A10.5.2 The following limits apply to questions submitted to the FSAE Rules Committee (1) No photograph, drawing or other attachment may exceed 100 KB in size (2) the total size of any question, with all attachments, must not exceed 1MB.

A10.6 Response Time

- A10.6.1 Please allow a minimum of two (2) weeks for a response. The Rules Committee will respond as quickly as possible, however responses to questions presenting new issues, or of unusual complexity, may take more than two weeks.
- A10.6.2 Please do not resend questions.

A10.7 Submission Addresses:

- A10.7.1 Teams entering Formula SAE competitions in North America
Send questions to: Kathleen McDonald, Formula SAE Consultant
Email: katklauz@aol.com
- A10.7.2 Teams entering only Formula SAE-Australasia:
Send questions to: SAE-A Organizers
Email: formulasae@sae-a.com.au
- A10.7.3 Teams entering only Formula SAE Brazil:
Send questions to: SAE Brazil Organizers
Email: formula.saebrasil@saebrasil.org.br
- A10.7.4 Teams entering only Formula SAE Italy:
Send questions to: Roberta Reggiani, Formula SAE Italy Manager,
Email: Roberta.reggiani@crf.it
- A10.7.5 *Teams entering only Formula Student:*
Submit questions to the Formula Student Questions Database
Website: <http://teams.formulastudent.com/faq/NewThread.aspx>
- A10.7.6 *Teams entering only Formula Student Germany:*
Submit questions to: Frank Roeske
Email: rules@formulastudent.de

APPENDIX S SAE TECHNICAL STANDARDS

The SAE Technical Standards Board (TSB) has made the following SAE Technical Standards available on line, **at no cost**, for use by Collegiate Design teams. Standards are important in all areas of engineering and we urge you to review these documents and to become familiar with their contents and use.

The technical documents listed below include both (1) standards that are identified in the rules and (2) standards that the TSB and the various rules committees believe are valuable references or which may be mentioned in future rule sets.

All Collegiate Design Series teams registered for competitions in North America have access to all the standards listed below - including standards not specific to your competition.

See FSAE Rule A3.11 “Technical Standards Access” for the access procedure.

SAE Technical Standards included in the CDS Rules

Baja SAE

J586 - Stop Lamps for Use on Motor Vehicles Less Than 2032 mm in Overall Width

J759 - Lighting Identification Code

J994 - Alarm - Backup – Electric Laboratory Tests

J1741 - Discriminating Back-Up Alarm Standard

Clean Snowmobile Challenge

J192 - Maximum Exterior Sound Level for Snowmobiles

J1161 - Sound Measurement – Off-Road Self-Propelled Work Machines Operator-Work Cycle

Formula Hybrid

J1318 - Gaseous Discharge Warning Lamp for Authorized Emergency, Maintenance and Service Vehicles

J1673 - High Voltage Automotive Wiring Assembly Design

Formula SAE

SAE 4130 steel is referenced but no specific standard is identified

SAE Grade 5 bolts are required but no specific standard is identified

Supermileage

J586 - Stop Lamps for Use on Motor Vehicles Less Than 2032 mm in Overall Width

SAE Technical Standards for Supplemental Use

Standards Relevant to Baja SAE

- J98 – Personal Protection for General Purpose Industrial Machines – Standard
- J183 – Engine Oil Performance and Engine Service Classification - Standard
- J306 – Automotive Gear Lubricant Viscosity Classification - Standard
- J429 – Mechanical and Material Requirements for Externally Threaded Fasteners – Standard
- J512 – Automotive Tube Fittings - Standard
- J517 – Hydraulic Hose - Standard
- J1166 – Sound Measurement – Off-Road Self-Propelled Work Machines Operator-Work Cycle
- J1194 – Rollover Protective Structures (ROPS) for Wheeled Agricultural Tractors
- J1362 – Graphical Symbols for Operator Controls and Displays on Off-Road Self-Propelled Work Machines - Standard
- J1614 – Wiring Distribution Systems for Construction, Agricultural and Off-Road Work Machines
- J1703 - Motor Vehicle Brake Fluid - Standard
- J2030 – Heavy Duty Electrical Connector Performance Standard
- J2402 – Road Vehicles – Symbols for Controls, Indicators and Tell-Tales – Standard

Standards Relevant to Clean Snowmobile Challenge

- J44 – Service Brake System Performance Requirements – Snowmobiles - Recommended Practice
- J45 – Brake System Test Procedure – Snowmobiles – Recommended Practice
- J68 – Tests for Snowmobile Switching Devices and Components - Recommended Practice
- J89 – Dynamic Cushioning Performance Criteria for Snowmobile Seats - Recommended Practice
- J92 – Snowmobile Throttle Control Systems – Recommended Practice
- J192 – Maximum Exterior Sound Level for Snowmobiles - Recommended Practice
- J288 – Snowmobile Fuel Tanks - Recommended Practice
- J1161 – Operational Sound Level Measurement Procedure for Snowmobiles - Recommended Practice
- J1222 – Speed Control Assurance for Snowmobiles - Recommended Practice
- J1279 – Snowmobile Drive Mechanisms - Recommended Practice
- J1282 – Snowmobile Brake Control Systems - Recommended Practice
- J2567 – Measurement of Exhaust Sound Levels of Stationary Snowmobiles - Recommended Practice

Standards Relevant to Formula SAE

- J183 – Engine Oil Performance and Engine Service Classification - Standard
- J306 – Automotive Gear Lubricant Viscosity Classification - Standard
- J429 – Mechanical and Material Requirements for Externally Threaded Fasteners – Standard
- J452 - General Information – Chemical Compositions, Mechanical and Physical Properties of SAE Aluminum Casting Alloys – Information Report
- J512 – Automotive Tube Fittings - Standard
- J517 – Hydraulic Hose - Standard
- J637 – Automotive V-Belt Drives – Recommended Practice
- J829 – Fuel Tank Filler Cap and Cap Retainer
- J1153 - Hydraulic Cylinders for Motor Vehicle Brakes – Test Procedure
- J1154 – Hydraulic Master Cylinders for Motor Vehicle Brakes - Performance Requirements - Standard
- J1703 - Motor Vehicle Brake Fluid - Standard
- J2045 – Performance Requirements for Fuel System Tubing Assemblies - Standard

J2053 – Brake Master Cylinder Plastic Reservoir Assembly for Road Vehicles – Standard

Standard Relevant to Formula Hybrid

J1772 – SAE Electric Vehicle and Plug in Hybrid Conductive Charge Coupler

Standard Relevant to all CDS Competitions

J1739 – Potential Failure Mode and Effects Analysis in Design (Design FMEA) Potential Failure Mode and Effects Analysis in Manufacturing and Assembly Processes (Process FMEA) and Potential Failure Mode and Effects Analysis for Machinery (Machinery FMEA)

2011 FORMULA SAE RULES

PART B – TECHNICAL REQUIREMENTS

ARTICLE 1: VEHICLE REQUIREMENTS & RESTRICTIONS

B1.1 Technical Inspection

The following requirements and restrictions will be enforced through technical inspection. Noncompliance must be corrected and the car re-inspected before the car is allowed to operate under power.

B1.2 Modifications and Repairs

B1.2.1 Once the vehicle has been presented for judging in the Cost or Design Events, or submitted for Technical Inspection, and until the vehicle is approved to compete in the dynamic events, i.e. all the inspection stickers are awarded, the only modifications permitted to the vehicle are those directed by the Inspector(s) and noted on the Inspection Form.

B1.2.2 Once the vehicle is approved to compete in the dynamic events, the **ONLY** modifications permitted to the vehicle are those listed below. They are also referenced in Part C of the Formula SAE Rules – Static Event Regulations.

- a. Adjustment of belts, chains and clutches
- b. Adjustment of brake bias
- c. Adjustment of the driver restraint system, head restraint, seat and pedal assembly
- d. Substitution of the head restraint or seat insert for different drivers
- e. Adjustment to engine operating parameters, e.g. fuel mixture and ignition timing
- f. Adjustment of mirrors
- g. Adjustment of the suspension where no part substitution is required, (except that springs, sway bars and shims may be changed)
- h. Adjustment of tire pressure
- i. Adjustment of wing angle, but not the location
- j. Replenishment of fluids
- k. Replacement of worn tires or brake pads
- l. The changing of wheels and tires for “wet” or “damp” conditions as allowed in Part D of the FSAE Rules – Dynamic Event Regulations.

B1.2.3 The vehicle must maintain all required specifications, e.g. ride height, suspension travel, braking capacity, sound level and wing location throughout the competition.

B1.2.4 Once the vehicle is approved for competition, any damage to the vehicle that requires repair, e.g. crash damage, electrical or mechanical damage will void the Inspection Approval. Upon the completion of the repair and before re-entering into any dynamic competition, the vehicle **MUST** be re-submitted to Technical Inspection for re-approval.

ARTICLE 2: GENERAL DESIGN REQUIREMENTS

B2.1 Vehicle Configuration

The vehicle must be open-wheeled and open-cockpit (a formula style body) with four (4) wheels that are not in a straight line.

B2.2 Bodywork

There must be no openings through the bodywork into the driver compartment from the front of the vehicle back to the roll bar main hoop or firewall other than that required for the cockpit opening. Minimal openings around the front suspension components are allowed.

B2.3 Wheelbase

The car must have a wheelbase of at least 1525 mm (60 inches). The wheelbase is measured from the center of ground contact of the front and rear tires with the wheels pointed straight ahead.

B2.4 Vehicle Track

The smaller track of the vehicle (front or rear) must be no less than 75% of the larger track.

B2.5 Visible Access

All items on the Inspection Form must be clearly visible to the technical inspectors without using instruments such as endoscopes or mirrors. Visible access can be provided by removing body panels or by providing removable access panels.

ARTICLE 3: DRIVER'S CELL**B3.0 Vehicle Structure - 2 Options**

*Teams may, at their option, design their vehicle to comply with either of two (2) separate, but related, sets of requirements and restrictions. Specifically, teams may elect to comply with **either**:*

*(1) Part B Article 3 "Drivers Cell" as defined below **or***

(2) Part AF "Alternate Frame Rules" as found in Appendix AF and on the FSAE website.

B3.0.1 *Notice Requirement – Teams planning to use the Part AF "Alternate Frame Rules" must notify the Rules Committee of their intent by November 1, 2010. The instructions for notification appear in Part AF. The Rules Committee will review the submission and notify the team if the request is granted. Part AF has significant analytical requirements and as it is still in development this application process will insure that the Committee can handle the workload and give teams the support they may require to show certification as well as insure the teams have the technical capability to analyze their design and prove compliance with the AF Rules.*

B3.0.2 *Alternate Frame Rules use requires the submission of the "Structural Requirements Certification Form (SRCF)" which **supersedes** the Rule B3.8 "Structural Equivalency Form".*

*Teams submitting a Structural Requirements Certification Form (SRCF) **do not** have to submit a Structural Equivalency Form (SEC).*

B3.1 General Requirements

Among other requirements, the vehicle's structure must include two roll hoops that are braced, a front bulkhead with support system and Impact Attenuator, and side impact structures.

B3.2 Definitions

The following definitions apply throughout the Rules document:

- Main Hoop - A roll bar located alongside or just behind the driver's torso.
- Front Hoop - A roll bar located above the driver's legs, in proximity to the steering wheel.

- Roll Hoops – Both the Front Hoop and the Main Hoop are classified as “Roll Hoops”
- Roll Hoop Bracing Supports – The structure from the lower end of the Roll Hoop Bracing back to the Roll Hoop(s).
- Frame Member - A minimum representative single piece of uncut, continuous tubing.
- Frame - The “Frame” is the fabricated structural assembly that supports all functional vehicle systems. This assembly may be a single welded structure, multiple welded structures or a combination of composite and welded structures.
- Primary Structure – The Primary Structure is comprised of the following Frame components: 1) Main Hoop, 2) Front Hoop, 3) Roll Hoop Braces *and Supports*, 4) Side Impact Structure, 5) Front Bulkhead, 6) Front Bulkhead Support System and 7) all Frame Members, guides and supports that transfer load from the Driver’s Restraint System into items 1 through 6.
- Major Structure of the Frame – The portion of the Frame that lies within the envelope defined by the Primary Structure. The upper portion of the Main Hoop and the Main Hoop *Bracing* are not included in defining this envelope.
- Front Bulkhead – A planar structure that defines the forward plane of the Major Structure of the Frame and functions to provide protection for the driver’s feet.
- Impact Attenuator – A deformable, energy absorbing device located forward of the Front Bulkhead.
- Side Impact Zone – The area of the side of the car extending from the top of the floor to 350 mm (13.8 inches) above the ground and from the Front Hoop back to the Main Hoop.

B3.3 Minimum Material Requirements

B3.3.1 Baseline Steel Material

The Primary Structure of the car must be constructed of:

Either: Round, mild or alloy, steel tubing (minimum 0.1% carbon) of the minimum dimensions specified in the following table,

Or: Approved alternatives per Rules B.3.4, B.3.5, B.3.6 and B.3.7.

ITEM or APPLICATION	OUTSIDE <i>DIMENSION</i> X WALL THICKNESS
Main & Front Hoops, Shoulder Harness Mounting Bar	Round 1.0 inch (25.4 mm) x 0.095 inch (2.4 mm) or Round 25.0 mm x 2.50 mm metric
Side Impact Structure, Front Bulkhead, Roll Hoop Bracing, Driver’s Restraint Harness Attachment (except as noted above)	Round 1.0 inch (25.4 mm) x 0.065 inch (1.65 mm) or Round 25.0 mm x 1.75 mm metric or Round 25.4 mm x 1.60 mm metric or Square 1.00 inch x 1.00 inch x 0.049 inch or Square 25.0 mm x 25.0 mm x 1.25 mm metric or Square 26.0 mm x 26.0 mm x 1.2 mm metric
Front Bulkhead Support, Main Hoop Bracing Supports	Round 1.0 inch (25.4 mm) x 0.049 inch (1.25 mm) or Round 25.0 mm x 1.5 mm metric or Round 26.0 mm x 1.2 mm metric

Note 1: The use of alloy steel does not allow the wall thickness to be thinner than that used for mild steel.

Note 2: For a specific application:

- Using tubing of the specified outside diameter but with greater wall thickness,

- OR of the specified wall thickness and a greater outside diameter,
- Or replacing round tubing with square tubing of the same or larger size to those listed above,

Are NOT rules deviation requiring approval.

Note 3: Except for inspection holes, any holes drilled in any regulated tubing require the submission of an SEF.

Note 4: *Baseline steel properties used for calculations to be submitted in an SEF may not be lower than the following:*

Bending and buckling strength calculations:

Young's Modulus (E) = 200 GPa (29,000 ksi)

Yield Strength (Sy) = 305 MPa (44.2 ksi)

Ultimate Strength (Su) = 365 MPa (52.9 ksi)

Welded monocoque attachment points or welded tube joint calculations:

Yield Strength (Sy) = 180 MPa (26ksi)

Ultimate Strength (Su) = 300 MPa (43.5 ksi)

*Where welded tubing reinforcements are required (e.g. inserts for bolt holes or material to support suspension cutouts) the tubing **must** retain the baseline cold rolled strength while using the welded strength for the additional reinforcement material.*

B3.4 Alternative Tubing and Material - General

B3.4.1 Alternative tubing geometry and/or materials may be used except that the Main Roll Hoop and Main Roll Hoop Bracing must be made from steel, i.e. the use of aluminum or titanium tubing or composites for these components is prohibited.

B3.4.2 *Titanium or magnesium on which welding has been utilized may not be used for any part of the Primary Structure.* This includes the attachment of brackets to the tubing or the attachment of the tubing to other components.

B3.4.3 If a team chooses to use alternative tubing and/or materials they must submit a “Structural Equivalency Form” per Rule B.3.8. The teams must submit calculations for the material they have chosen, demonstrating equivalence to the minimum requirements found in Section B.3.3.1 for yield and ultimate strengths in bending, buckling and tension, for buckling modulus and for energy dissipation. (The Buckling Modulus is defined as EI, where, E = modulus of Elasticity, and I = area moment of inertia about the weakest axis.)

B3.4.4 Tubing cannot be of thinner wall thickness than listed in B.3.5 or B.3.6.

B3.5 Alternative Steel Tubing
 Minimum Wall Thickness Allowed:

MATERIAL & APPLICATION	MINIMUM WALL THICKNESS
Steel Tubing for Front and Main Roll Hoops, and Shoulder Harness Mounting Bar	2.0 mm (0.079 inch)
Steel Tubing for Roll Hoop Bracing, Roll Hoop Bracing Supports, Side Impact Structure, Front Bulkhead, Front Bulkhead Support, and Driver’s Harness Attachment (except as noted above)	1.2 mm (0.047 inch)

Note 1: All steel is treated equally - there is no allowance for alloy steel tubing, e.g. SAE 4130, to have a thinner wall thickness than that used with mild steel.

Note 2: To maintain EI with a thinner wall thickness than specified in B.3.3.1, the outside diameter **MUST** be increased.

Note 3: To maintain the equivalent yield and ultimate tensile strength the same cross-sectional area of steel as *the baseline tubing specified in B.3.3.1* **MUST** be maintained.

B3.6 Aluminum Tubing Requirements

B3.6.1 Minimum Wall Thickness: Aluminum Tubing 3.0 mm (0.118 inch)

B3.6.2 The equivalent yield strength must be considered in the “as-welded” condition, (Reference: WELDING ALUMINUM (latest Edition) by the Aluminum Association, or THE WELDING HANDBOOK, Vol . 4, 7th Ed., by The American Welding Society), unless the team demonstrates and shows proof that the frame has been properly solution heat treated and artificially aged.

B3.6.3 Should aluminum tubing be solution heat-treated and age hardened to increase its strength after welding; the team must supply sufficient documentation as to how the process was performed. This includes, but is not limited to, the heat-treating facility used, the process applied, and the fixturing used.

B3.7 Composite Materials

B3.7.1 If any composite or other material is used, the team must present documentation of material type, e.g. purchase receipt, shipping document or letter of donation, and of the material properties. Details of the composite lay-up technique as well as the structural material used (cloth type, weight, and resin type, number of layers, core material, and skin material if metal) must also be submitted. The team must submit calculations demonstrating equivalence of their composite structure to one of similar geometry made to the minimum requirements found in Section B.3.3.1. Equivalency calculations must be submitted for energy dissipation, yield and ultimate strengths in bending, buckling, and tension. Submit the completed “Structural Equivalency Form” per Section B.3.8.

B3.7.2 Composite materials are not allowed for the Main Hoop or the Front Hoop.

B3.8 Structural Equivalency and Structural Equivalency Form (SEF)

All equivalency calculations must prove equivalency relative to steel grade SAE/AISI 1010.

- B3.8.1 ALL TEAMS MUST SUBMIT A STRUCTURAL EQUIVALENCY FORM (SEF), even if they are NOT planning to use alternative materials or tubing sizes to those specified in B.3.3.1 Baseline Steel Materials.
- B3.8.2 The use of alternative materials or tubing sizes to those specified in B.3.3.1 “Baseline Steel Material,” is allowed, provided they have been judged by a technical review to have equal or superior properties to those specified in B.3.3.1.
- B3.8.3 Approval of alternative material or tubing sizes will be based upon the engineering judgment and experience of the chief technical inspector or his appointee.
- B3.8.4 The technical review is initiated by completing the “Structural Equivalency Form” (SEF) using the format given in Appendix B-1.
- B3.8.5 Structural Equivalency Form – Submission
- Address – SEF’s must be submitted to the officials at the competition you are entering at the address shown in the Appendix or indicated at the competition website.
 - Due Date – SEF’s must be submitted no later than the date given in the “Action Deadlines” indicated on the competition website. Teams that submit their Structural Equivalency Form after the due date for the competition will be penalized 10 points per day up to a maximum of 50 points, which will be taken off the team’s Total Score.
 - Acknowledgement – North America competitions – SEF’s submitted for vehicles entered into competitions held in North America will be acknowledged upon receipt.

Do Not Resubmit SEF’s unless instructed to do so.

- B3.8.6 Vehicles completed under an approved SEF must be fabricated in accordance with the materials and processes described in the SEF.
- B3.8.7 Teams must bring a copy of the approved SEF with them to Technical Inspection.

Comment - The resubmission of SEFs that were written and submitted for a competition in a previous year is strongly discouraged. Each team is expected to perform their own tests and calculations and to submit SEFs based on their original work. Understanding the engineering that justifies the equivalency is essential to discussing your work with the officials.

B3.9 Main and Front Roll Hoops – General Requirements

- B3.9.1 The driver’s head and hands must not contact the ground in any rollover attitude.
- B3.9.2 The Frame must include both a Main Hoop and a Front Hoop as shown in Figure 1.
- B3.9.3 When seated normally and restrained by the Driver’s Restraint System, the helmet of a 95th percentile male (anthropometrical data) and all of the team’s drivers must:
- Be a minimum of 50.8 mm (2 inches) from the straight line drawn from the top of the main hoop to the top of the front hoop. (Figure 1a)
 - Be a minimum of 50.8 mm (2 inches) from the straight line drawn from the top of the main hoop to the lower end of the main hoop bracing if the bracing extends rearwards. (Figure 1b)
 - Be no further rearwards than the rear surface of the main hoop if the main hoop bracing extends forwards. (Figure 1c)

95th Percentile Male Template Dimensions

A two dimensional template used to represent the 95th percentile male is made to the following dimensions:

- A circle of diameter 200 mm (7.87 inch) will represent the hips and buttocks.
- A circle of diameter 200 mm (7.87 inch) will represent the shoulder/cervical region.
- A circle of diameter 300 mm (11.81 inch) will represent the head (with helmet).
- A straight line measuring 490 mm (19.29 inch) will connect the centers of the two 200 mm circles.
- A straight line measuring 280 mm (11.02 inch) will connect the centers of the upper 200 mm circle and the 300 mm head circle.

- B3.9.4 The 95th percentile male template will be positioned as follows: (See Figure 2.)
- The seat will be adjusted to the rearmost position,
 - The bottom 200 mm circle will be placed at the junction of the seat back and the seat bottom, tangential to both.
 - The middle 200 mm circle, representing the shoulders, will be positioned on the seat back.
 - The upper 300 mm circle will be positioned no more than 25.4 mm (1 inch) away from the head restraint (i.e. where the driver's helmet would normally be located while driving).
- B3.9.5 If the requirements of B.3.9.3 are not met with the 95th percentile male template, the car will NOT receive a Technical Inspection Sticker and will not be allowed to compete in the dynamic events.
- B3.9.6 Drivers who do not meet the helmet clearance requirements of B.3.9.3 will not be allowed to drive in the competition.
- B3.9.7 The minimum radius of any bend, measured at the tube centerline, must be at least three times the tube outside diameter. Bends must be smooth and continuous with no evidence of crimping or wall failure.
- B3.9.8 The Main Hoop and Front Hoop must be securely integrated into the Primary Structure using gussets and/or tube triangulation.
- B3.10 Main Hoop**
- B3.10.1 The Main Hoop must be constructed of a single piece of uncut, continuous, closed section steel tubing per Rule B.3.3.1.
- B3.10.2 The use of aluminum alloys, titanium alloys or composite materials for the Main Hoop is prohibited.
- B3.10.3 The Main Hoop must extend from the lowest Frame Member on one side of the Frame, up, over and down the lowest Frame Member on the other side of the Frame.
- B3.10.4 In the side view of the vehicle, the portion of the Main Roll Hoop that lies above its attachment point to the Major Structure of the Frame must be within ten degrees (10°) of the vertical.
- B3.10.5 In the front view of the vehicle, the vertical members of the Main Hoop must be at least 380 mm (15 inch) apart (inside dimension) at the location where the Main Hoop is attached to the Major Structure of the Frame.

B3.11 Front Hoop

- B3.11.1 The Front Hoop must be constructed of closed section metal tubing per Rule B.3.3.1.
- B3.11.2 The Front Hoop must extend from the lowest Frame Member on one side of the Frame, up, over and down to the lowest Frame Member on the other side of the Frame.
- B3.11.3 With proper gusseting and/or triangulation, it is permissible to fabricate the Front Hoop from more than one piece of tubing.
- B3.11.4 The top-most surface of the Front Hoop must be no lower than the top of the steering wheel in any angular position.
- B3.11.5 The Front Hoop must be no more than 250 mms (9.8 inches) forward of the steering wheel. This distance shall be measured horizontally, on the vehicle centerline, from the rear surface of the Front Hoop to the forward most surface of the steering wheel rim with the steering in the straight-ahead position.
- B3.11.6 In side view, no part of the Front Hoop can be inclined at more than twenty degrees (20°) from the vertical.

B3.12 Main Hoop Bracing

- B3.12.1 Main Hoop braces must be constructed of closed section steel tubing per Rule B.3.3.1.
- B3.12.2 The Main Hoop must be supported by two braces extending in the forward or rearward direction on both the left and right sides of the Main Hoop.
- B3.12.3 In the side view of the Frame, the Main Hoop and the Main Hoop braces must not lie on the same side of the vertical line through the top of the Main Hoop, i.e. if the Main Hoop leans forward, the braces must be forward of the Main Hoop, and if the Main Hoop leans rearward, the braces must be rearward of the Main Hoop.
- B3.12.4 The Main Hoop braces must be attached as near as possible to the top of the Main Hoop but not more than 160 mm (6.3 in) below the top-most surface of the Main Hoop. The included angle formed by the Main Hoop and the Main Hoop braces must be at least thirty degrees (30°). See Figure 3.
- B3.12.5 The Main Hoop braces must be straight, i.e. without any bends.
- B3.12.6 The attachment of the Main Hoop braces must be capable of transmitting all loads from the Main Hoop into the Major Structure of the Frame without failing. From the lower end of the braces there must be a properly triangulated structure back to the lowest part of the Main Hoop *and the node at which the upper side impact tube meets the Main Hoop*. This structure must meet the minimum requirements for Main Hoop Bracing Supports (see Rule B.3.3) or an SEF approved alternative. Bracing loads must not be fed solely into the engine, transmission or differential, or through suspension components.
- B3.12.7 If any item which is outside the envelope of the Primary Structure is attached to the Main Hoop braces, then additional bracing must be added to prevent bending loads in the braces in any rollover attitude.

B3.13 Front Hoop Bracing

- B3.13.1 Front Hoop braces must be constructed of material per Rule B.3.3.1.

- B3.13.2 The Front Hoop must be supported by two braces extending in the forward direction on both the left and right sides of the Front Hoop.
- B3.13.3 The Front Hoop braces must be constructed such that they protect the driver's legs and should extend to the structure in front of the driver's feet.
- B3.13.4 The Front Hoop braces must be attached as near as possible to the top of the Front Hoop but not more than 50.8 mm (2 in) below the top-most surface of the Front Hoop. See Figure 3.
- B3.13.5 If the Front Hoop leans rearwards by more than ten degrees (10°) from the vertical, it must be supported by additional bracing to the rear. This bracing must be constructed of material per Rule B.3.3.1.
- B3.14 Other Bracing Requirements**
Where the braces are not welded to steel Frame Members, the braces must be securely attached to the Frame using 8 mm Grade 8.8 (5/16 in Grade 5), or stronger, bolts. Mounting plates welded to the Roll Hoop braces must be at least 2.0 mm (0.080 in) thick steel.
- B3.15 Other Side Tube Requirements**
If there is a Roll Hoop brace or other frame tube alongside the driver, at the height of the neck of any of the team's drivers, a metal tube or piece of sheet metal must be firmly attached to the Frame to prevent the drivers' shoulders from passing under the roll hoop brace or frame tube, and his/her neck contacting this brace or tube.
- B3.16 Mechanically Attached Roll Hoop Bracing**
- B3.16.1 Roll Hoop bracing may be mechanically attached.
- B3.16.2 Any non-permanent joint at either end must be either a double-lug joint as shown in Figures 4 and 5, or a sleeved butt joint as shown in Figure 6.
- B3.16.3 The threaded fasteners used to secure non-permanent joints are considered critical fasteners and must comply with Article B.14.
- B3.16.4 No spherical rod ends are allowed.
- B3.16.5 For double-lug joints, each lug must be at least 4.5 mm (0.177 in) thick steel, measure 25 mm (1.0 in) minimum perpendicular to the axis of the bracing and be as short as practical along the axis of the bracing.
- B3.16.6 All double-lug joints, whether fitted at the top or bottom of the tube, must include a capping arrangement (Figures 4 & 5).
- B3.16.7 In a double-lug joint the pin or bolt must be 10 mm Grade 9.8 (3/8 in. Grade 8) minimum. The attachment holes in the lugs and in the attached bracing must be a close fit with the pin or bolt.
- B3.16.8 For sleeved butt joints (Figure 6), the sleeve must have a minimum length of 76 mm (3 inch), 38 mm (1.5 inch) either side of the joint, and be a close-fit around the base tubes. The wall thickness of the sleeve must be at least that of the base tubes. The bolts must be 6 mm Grade 9.8 (1/4 inch Grade 8) minimum. The holes in the sleeves and tubes must be a close-fit with the bolts.

B3.17 Frontal Impact Structure

- B3.17.1 The driver's feet must be completely contained within the Major Structure of the Frame. While the driver's feet are touching the pedals, in side and front views no part of the driver's feet can extend above or outside of the Major Structure of the Frame.
- B3.17.2 Forward of the Front Bulkhead must be an energy-absorbing Impact Attenuator.

B3.18 Bulkhead

- B3.18.1 The Front Bulkhead must be constructed of closed section tubing per Rule B.3.3.1.
- B3.18.2 Except as allowed by B.3.22.2, The Front Bulkhead must be located forward of all non-crushable objects, e.g. batteries, master cylinders, hydraulic reservoirs.
- B3.18.3 The Front Bulkhead must be located such that the soles of the driver's feet, when touching but not applying the pedals, are rearward of the bulkhead plane. (This plane is defined by the forward-most surface of the tubing.) Adjustable pedals must be in the forward most position.

B3.19 Front Bulkhead Support

- B3.19.1 The Front Bulkhead must be securely integrated into the Frame.
- B3.19.2 The Front Bulkhead must be supported back to the Front Roll Hoop by a minimum of three (3) Frame Members on each side of the vehicle with one at the top (within 50.8 mm (2 inches) of its top-most surface), one (1) at the bottom, and one (1) as a diagonal brace to provide triangulation.
- B3.19.3 The triangulation must be node-to-node, with triangles being formed by the Front Bulkhead, the diagonal and one of the other two required Front Bulkhead Support Frame Members.
- B3.19.4 All the Frame Members of the Front Bulkhead Support system listed above must be constructed of closed section tubing per Section B.3.3.1.

B3.20 Impact Attenuator

- B3.20.1 The Impact Attenuator must be:
 - a. Installed forward of the Front Bulkhead.
 - b. At least 200 mm (7.8 in) long, with its length oriented along the fore/aft axis of the Frame.
 - c. At least 100 mm (3.9 in) high and 200 mm (7.8 in) wide for a minimum distance of 200 mm (7.8 in) forward of the Front Bulkhead.
 - d. Such that it cannot penetrate the Front Bulkhead in the event of an impact.
 - e. Attached securely and directly to the Front Bulkhead and not by being part of non-structural bodywork.
- B3.20.2 The attachment of the Impact Attenuator must be constructed to provide an adequate load path for transverse and vertical loads in the event of off-center and off-axis impacts.
- B3.20.3 The attachment of the Impact Attenuator to a monocoque structure requires an approved "Structural Equivalency Form" per Article B.3.8 that shows equivalency to a minimum of four (4) 8 mm Grade 8.8 (5/16 inch Grade 5) bolts..
- B3.20.4 On all cars, a 1.5 mm (0.060 in) solid steel or 4.0 mm (0.157 in) solid aluminum "anti-intrusion plate" must be integrated into the Impact Attenuator. If the IA plate is bolted to the Front Bulkhead, it must

be the same size as the outside dimensions of the Front Bulkhead. If it is welded to the Front Bulkhead, it must extend at least to the centerline of the Front Bulkhead tubing.

- B3.20.5 If the anti-intrusion is not integral with the frame, i.e. welded, a minimum of four (4) 8 mm Grade 8.8 (5/16 inch Grade 5) bolts must attach the Impact Attenuator to the Front Bulkhead.
- B3.20.6 Alternative designs of the anti-intrusion plate required by B.3.20.4 that do not comply with the minimum specifications given above require an approved “Structural Equivalency Form” per Article B.3.8. *Equivalency must also be proven for perimeter shear strength of the proposed design.*

B3.21 Impact Attenuator Data Requirement

- B3.21.1 The team must submit test data to show that their Impact Attenuator, when mounted on the front of a vehicle with a total mass of 300 kgs (661 lbs) and run into a solid, non-yielding impact barrier with a velocity of impact of 7.0 metres/second (23.0 ft/sec), would give an average deceleration of the vehicle not to exceed 20 g’s, with a peak deceleration less than or equal to 40 g’s. *Total energy absorbed must meet or exceed 7350 Joules.*

Note: These are the attenuator functional requirements not test requirements. Quasi-static testing is allowed.

- B3.21.2 When using acceleration data, the average deceleration must be calculated based on the raw data. The peak deceleration can be assessed based on the raw data, and if peaks above the 40g limit are apparent in the data, it can then be filtered with a Channel Filter Class (CFC) 60 (100 Hz) filter per SAE Recommended Practice J211 “Instrumentation for Impact Test”, or a 100 Hz, 3rd order, lowpass Butterworth (-3dB at 100 Hz) filter.
- B3.21.3 A schematic of the test method must be supplied along with photos of the attenuator before and after testing.
- B3.21.4 The test piece must be presented at technical inspection for comparison to the photographs and the attenuator fitted to the vehicle.
- B3.21.5 The test data and calculations must be submitted electronically in Adobe Acrobat ® format (*.pdf file) to the address and by the date provided in the Action Deadlines provided on the relevant competition website. This material must be a single file (text, drawings, data or whatever you are including).
- B3.21.6 The Impact Attenuator Data must be named as follows: carnumber_schoolname_competition code_IAD.pdf using the assigned car number, the complete school name and competition code [Example: 087_University of SAE_FSAEM_IAD.pdf]

Competition Codes are listed in Rule A.2.6

- B3.21.7 Teams that submit their Impact Attenuator Data Report after the due date will be penalized 10 points per day up to a maximum of 50 points, which will be taken off the team’s Total Score.
- B3.21.8 Impact Attenuator Reports will be evaluated by the organizers and the evaluations will be passed to the Design Event Captain for consideration in that event.
- B3.21.9 *During the test, the attenuator must be attached to the anti intrusion plate using the intended vehicle attachment method. The anti-intrusion plate must be spaced at least 50 mm (2 inches) from any rigid*

surface. No part of the anti-intrusion plate may permanently deflect more than 25.1 mm (1 inch) beyond the position of the anti-intrusion plate before the test.

Note: The 25.4 mm (1 inch) spacing represents the front bulkhead support and insures that the plate does not intrude excessively into the cockpit

B3.21.10 Dynamic Tests - Dynamic testing may only be done using (1) university owned, dedicated test equipment/facilities (drop tower, pendulum facility, sled) or (2) the equipment/facilities of a corporate or commercial test site. The use of team built/jury rigged dynamic test equipment or systems of any type is absolutely prohibited and the results obtained from such tests are considered invalid and will not be accepted.

Quasi –static Tests - Quasi-static testing may be performed using the universities facilities/equipment, but teams are advised to exercise due care when performing all tests.

B3.21.11 Standard Attenuator – If an officially approved impact attenuator design is posted to the organizer’s website teams may choose to build that style of impact attenuator and need not submit test data with their IAD Report. The other requirements of the IAD Report must still be submitted including, but not limited to, photos of the team’s actual attenuator with evidence that it meets the design criteria given on the website.

Note – It is the intention of the Rules Committee to post “pre-approved” impact attenuator designs to the FSAE website to reduce the burden on teams performing design iterations and testing of impact attenuators. The pre-approved designs are still under development so please visit the FSAE website for details.

B3.22 Non-Crushable Objects

B3.22.1 Except as allowed by B3.22.2, all non-crushable objects (e.g. batteries, master cylinders, hydraulic reservoirs) must be rearward of the bulkhead. No non-crushable objects are allowed in the impact attenuator zone.

B3.22.2 The front wing and wing supports may be forward of the Front Bulkhead, but may NOT be located in or pass through the Impact Attenuator. If the wing supports are in front of the Front Bulkhead, the supports must be included in the test of the Impact Attenuator for B.3.21.

B3.23 Front Bodywork

B3.23.1 Sharp edges on the forward facing bodywork or other protruding components are prohibited.

B3.23.2 All forward facing edges on the bodywork that could impact people, e.g. the nose, must have forward facing radii of at least 38 mm (1.5 inches). This minimum radius must extend to at least forty-five degrees (45°) relative to the forward direction, along the top, sides and bottom of all affected edges.

B3.24 Side Impact Structure for Tube Frame Cars

The Side Impact Structure must meet the requirements listed below.

B3.24.1 The Side Impact Structure for tube frame cars must be comprised of at least three (3) tubular members located on each side of the driver while seated in the normal driving position, as shown in Figure 7.

B3.24.2 The three (3) required tubular members must be constructed of material per Section B.3.3.1.

B3.24.3 The locations for the three (3) required tubular members are as follows:

- The upper Side Impact Structural member must connect the Main Hoop and the Front Hoop at a height between 300 mm (11.8 inch) and 350 mm (13.8 inch) above the ground with a 77kg (170 pound) driver seated in the normal driving position. The upper frame rail may be used as this member if it meets the height, diameter and thickness requirements.
- The lower Side Impact Structural member must connect the bottom of the Main Hoop and the bottom of the Front Hoop. The lower frame rail/frame member may be this member if it meets the diameter and wall thickness requirements.
- The diagonal Side Impact Structural member must connect the upper and lower Side Impact Structural members forward of the Main Hoop and rearward of the Front Hoop.

B3.24.4 With proper gusseting and/or triangulation, it is permissible to fabricate the Side Impact Structural members from more than one piece of tubing.

B3.24.5 Alternative geometry that does not comply with the minimum requirements given above requires an approved “Structural Equivalency Form” per Rule B.3.8.

B3.25 Inspection Holes

B3.25.1 The Technical Inspectors may check the compliance of all tubes. This may be done by the use of ultrasonic testing or by the drilling of inspection holes at the inspector’s request.

B3.26 Monocoque General Requirements

All equivalency calculations must prove equivalency relative to steel grade SAE/AISI 1010.

B3.26.1 All sections of the rules apply to monocoque structures except for the following sections which supplement or supersede other rule sections.

B3.26.2 Monocoque construction requires an approved Structural Equivalency Form, per Section B.3.8. The form must demonstrate that the design is equivalent to a welded frame in terms of energy dissipation, yield and ultimate strengths in bending, buckling and tension. Information must include: material type(s), cloth weights, resin type, fiber orientation, number of layers, core material, and lay-up technique. The 3 point bend test and shear test data and pictures must also be included as per B.3.28 Monocoque Laminate Testing. The Structural Equivalency must address each of the items below. Data from the laminate testing results must be used as the basis for any strength or stiffness calculations.

B3.26.3 Composite and metallic monocoques have the same requirements.

B3.26.4 Composite monocoques must meet the materials requirements in Rule B.3.7 Composite Materials.

B3.27 Monocoque Buckling Modulus – Equivalent Flat Panel Calculation

When specified in the rules, the EI of the monocoque must be calculated as the EI of a flat panel with the same composition as the monocoque about the neutral axis of the laminate. The curvature of the panel and geometric cross section of the monocoque must be ignored for these calculations.

Note: Calculations of EI that do not reference B.3.27 may take into account the actual geometry of the monocoque.

B3.28 Monocoque Laminate Testing

Teams must build a representative section of the *monocoque side impact zone (defined in B3.31)* side as a flat panel and perform a 3 point bending test on this panel. They must prove by physical test that

a section 200mm(7.9 inches) x 500 mm (19.7 inches) has at least the same properties as a baseline steel side impact tube (See B.3.3.1 “Baseline Steel Materials”) for bending stiffness and two side impact tubes for yield and ultimate strength. The data from these tests and pictures of the test samples must be included in the SEF. The test specimen must be presented at technical inspection. *If the test specimen does not meet these requirements then the monocoque side impact zone must be strengthened appropriately.*

Note: Teams are advised to make an equivalent test with the base line steel tubes such that any compliance in the test rig can be accounted for, if necessary.

B3.29 Monocoque Front Bulkhead

See Rule B.3.26 for general requirements that apply to all aspects of the monocoque. *In addition when modeled as a flat plate the EI of the front bulkhead about both vertical and lateral axis must be equivalent to that of the tubes specified for the front bulkhead under B3.18. Furthermore any front bulkhead which supports the IA plate must have a perimeter shear strength equivalent to a 1.5 mm thick steel plate.*

B3.30 Monocoque Front Bulkhead Support

B3.30.1 In addition to proving that the strength of the monocoque is adequate, the monocoque must have equivalent EI to the sum of the EI of the six(6) baseline steel tubes that it replaces.

B3.30.2 The EI of the vertical side of the front bulkhead support structure must be equivalent to at least the EI of one baseline steel tube that it replaces when calculated as per rule B.3.27 Monocoque Buckling Modulus.

B3.30.3 The perimeter shear strength of the monocoque laminate in the front bulkhead support structure should be at least 4 kN (880 pounds) for a section with a diameter of 25 mm (1 inch). This must be proven by a physical test by measuring the force required to pull or push a 25mm (1 inch) diameter object through a sample of laminate and the results include in the SEF

-

B3.31 Monocoque Side Impact

B3.31.1 In addition to proving that the strength of the monocoque is adequate, the side of the monocoque must have equivalent EI to the sum of the EI of the three (3) baseline steel tubes that it replaces.

B3.31.2 The side of the monocoque between the upper surface of the floor and 350 mm (13.8 inches) above the ground (Side Impact Zone) must have an EI of at least 50% of the sum of the EI of the three (3) baseline steel tubes that it replaces when calculated as per Rule B.3.27 Monocoque Buckling Modulus.

B3.31.3 The perimeter shear strength of the monocoque laminate should be at least 7.5 kN (1700 pounds) for a section with a diameter of 25 mm (1 inch). This must be proven by physical test by measuring the force required to pull or push a 25 mm (1 inch) diameter object through a sample of laminate and the results included in the SEF.

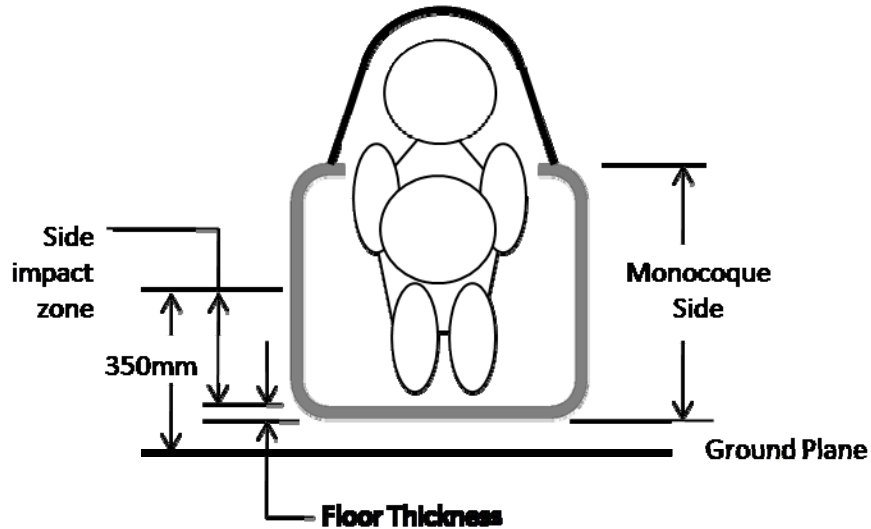

B3.32 Monocoque Main Hoop

B3.32.1 The Main Hoop must be constructed of a single piece of uncut, continuous, closed section steel tubing per B3.3.1 and extend down to the bottom of the monocoque.

B3.32.2 The Main Hoop must be *mechanically* attached at the top and bottom of the monocoque and at intermediate locations as needed to show equivalency.

B3.32.3 Mounting plates welded to the Roll Hoop shall be at least 2.0 mm (0.080 inch) thick steel.

B3.32.4 Attachment of the Main Hoop to the monocoque must comply with B3.37.

B3.33 Monocoque Front Hoop

B3.33.1 Composite materials are not allowed for the front hoop. See Rule B.3.26 for general requirements that apply to all aspects of the monocoque.

B3.33.2 Attachment of the Front Hoop to the monocoque must comply with Rule B3.37.

B3.34 Monocoque Front and Main Hoop Bracing

B3.34.1 See Rule B3.26 for general requirements that apply to all aspects of the monocoque.

B3.34.2 Attachment of tubular Front or Main Hoop Bracing to the monocoque must comply with Rule B3.37.

B3.35 Monocoque Impact Attenuator Attachment

The attachment of the Impact Attenuator to a monocoque structure requires an approved “Structural Equivalency Form” per Rule B3.8 that shows the equivalency to a minimum of four (4) 8 mm Grade 8.8 (5/16 inch Grade 5) bolts.

B3.36 Monocoque Impact Attenuator Anti-intrusion Plate

See Rule B3.26 for general requirements that apply to all aspects of the monocoque and Rule B3.20.6 for alternate anti-intrusion plate designs.

B3.37 Monocoque Attachments

B3.37.1 In any direction, each attachment point between the monocoque and the other primary structure must be able to carry a load of 30kN.

- B3.37.2 The laminate, mounting plates, backing plates and inserts must have sufficient shear area, weld area and strength to carry the specified 30kN load in any direction. *Data obtained from the laminate perimeter shear strength test (B3.31.3) should be used to prove adequate shear area is provided*
- B3.37.3 Each attachment point requires a minimum of two (2) M8 grade 8.8 (or 5/16 inch Grade 5) bolts.
- B3.37.4 *Each attachment point requires steel backing plates with a minimum thickness of 2 mm. Alternate materials may be used for backing plates if equivalency is approved.*
- B3.37.5 The Front Hoop Bracing, Main Hoop Bracing and Main Hoop Bracing Supports only may use one (1) 10 mm Grade 8.8 (3/8 inch Grade 5) bolt as an alternative to B.3.37.3 if the bolt is on the centerline of tube similar to the figure below.

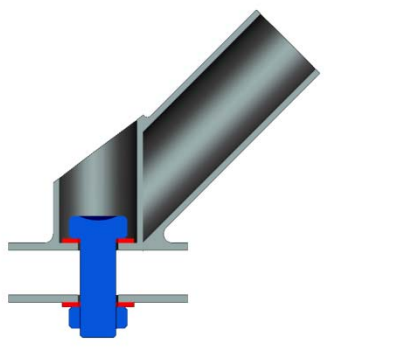

- B3.37.6 No crushing of the core is permitted
 - B3.37.7 Main Hoop bracing attached to a monocoque (i.e. not welded to a rear space frame) is always considered “mechanically attached” and must comply with Rule B.3.16.
- B3.38 Monocoque Driver’s harness Attachment Points**
- B3.38.1 *The monocoque attachment points for the shoulder and lap belts must support a load of 13 kN (3000 pounds) before failure.*
 - B3.38.2 *The monocoque attachment points for the ant-submarine belts must support a load of 6.5 kN (1500 pounds) before failure.*
 - B3.38.3 *If the lap belts and anti-submarine belts are attached to the same attachment point, then this point must support a load of 19.5 kN (4500 pounds) before failure.*
 - B3.38.4 *The strength of lap belt attachment and shoulder belt attachment must be proven by physical test where the required load is applied to a representative attachment point where the proposed layup and attachment bracket is used.*

ARTICLE 4: COCKPIT

B4.1 Cockpit Opening

- B4.1.1 In order to ensure that the opening giving access to the cockpit is of adequate size, a template shown in Figure 8 will be inserted into the cockpit opening. It will be held horizontally and inserted vertically until it has passed below the top bar of the Side Impact Structure (or until it is 350 mm (13.8 inches) above the ground for monocoque cars). *No fore and aft translation of the template will be permitted during insertion.*

B4.1.2 During this test, the steering wheel, steering column, seat and all padding may be removed. The firewall may not be moved or removed.

B4.2 Cockpit Internal Cross Section:

B4.2.1 A free vertical cross section, which allows the template shown in Figure 9 to be passed horizontally through the cockpit to a point 100 mm (4 inches) rearwards of the face of the rearmost pedal when in the inoperative position, must be maintained over its entire length. If the pedals are adjustable, they will be put in their most forward position.

B4.2.2 The template, with maximum thickness of 7mm (0.275 inch), will be held vertically and inserted into the cockpit opening rearward of the Front Roll Hoop, as close to the Front Roll Hoop as the car's design will allow.

B4.2.3 The only items that may be removed for this test are the steering wheel, and any padding required by Rule B5.7 "Driver's Leg Protection" that can be easily removed without the use of tools with the driver in the seat. The seat may NOT be removed.

B4.2.4 Teams whose cars do not comply with B4.1 or B4.2 will not be given a Technical Inspection Sticker and will NOT be allowed to compete in the dynamic events.

Note: Cables, wires, hoses, tubes, etc. must not impede the passage of the templates required by B4.1 and B4.2.

B4.3 Driver's Seat

B4.3.1 The lowest point of the driver's seat must be no lower than the bottom surface of the lower frame rails or by having a longitudinal tube (or tubes) that meets the requirements for Side Impact tubing, passing underneath the lowest point of the seat.

B4.3.2 When seated in the normal driving position, adequate heat insulation must be provided to ensure that the driver will not contact any metal or other materials which may become heated to a surface temperature above sixty degrees C (60°C). The insulation may be external to the cockpit or incorporated with the driver's seat or firewall. The design must show evidence of addressing all three (3) types of heat transfer, namely conduction, convection and radiation, with the following between the heat source, e.g. an exhaust pipe or coolant hose/tube and the panel that the driver could contact, e.g. the seat or floor:

a. Conduction Isolation by:

- i. No direct contact between the heat source and the panel, or
- ii. A heat resistant, conduction isolation material with a minimum thickness of 8 mm (0.3 in) between the heat source and the panel.

b. Convection Isolation by a minimum air gap of 25 mm (1 inch) between the heat source and the panel

c. Radiation Isolation by:

- i. A solid metal heat shield with a minimum thickness of 0.4 mm (0.015 in) or
- ii. Reflective foil or tape when combined with a.ii above.

B4.4 Floor Close-out

All vehicles must have a floor closeout made of one or more panels, which separate the driver from the pavement. If multiple panels are used, gaps between panels are not to exceed 3 mm (1/8 inch). The closeout must extend from the foot area to the firewall and prevent track debris from entering the car. The panels must be made of a solid, non-brittle material.

B4.5 Firewall

B4.5.1 A firewall must separate the driver compartment from all components of the fuel supply, the engine oil and the liquid cooling systems. It must protect the neck of the tallest driver. It must extend sufficiently far upwards and/or rearwards such that any point less than 100 mm (4 ins.) above the bottom of the helmet of the tallest driver shall not be in direct line of sight with any part of the fuel system, the cooling system or the engine oil system.

B4.5.2 The firewall must be a non-permeable surface made from a *rigid*, fire resistant material.

B4.5.3 Any firewall must seal completely against the passage of fluids, especially at the sides and the floor of the cockpit, i.e. there can be no holes in a firewall through which seat belts pass.

B4.5.4 Pass-throughs for wiring, cables, etc. are allowable if grommets are used to seal the pass-throughs. Also, multiple panels may be used to form the firewall but must be sealed at the joints.

B4.6 Accessibility of Controls

All vehicle controls, including the shifter, must be operated from inside the cockpit without any part of the driver, e.g. hands, arms or elbows, being outside the planes of the Side Impact Structure defined in Rule B3.24 and B3.31.

B4.7 Driver Visibility**B4.7.1 General Requirement**

The driver must have adequate visibility to the front and sides of the car. With the driver seated in a normal driving position he/she must have a minimum field of vision of two hundred degrees (200°) (a minimum one hundred degrees (100°) to either side of the driver). The required visibility may be obtained by the driver turning his/her head and/or the use of mirrors.

B4.7.2 Mirrors

If mirrors are required to meet Rule B4.7.1, they must remain in place and adjusted to enable the required visibility throughout all dynamic events.

B4.8 Driver Egress

All drivers must be able to exit to the side of the vehicle in no more than 5 seconds. Egress time begins with the driver in the fully seated position, hands in driving position on the connected steering wheel and wearing the required driver equipment. Egress time will stop when the driver has both feet on the pavement.

ARTICLE 5: DRIVERS EQUIPMENT (BELTS AND COCKPIT PADDING)**B5.1 Belts - General****B5.1.1 Definitions**

- a. A 5-point system – consists of a 76 mm (3 inch) wide lap belt, approximately 76 mm (3 inch) wide shoulder straps and a single approximately 51 mm (2 inch) wide anti-submarine strap. The single anti-submarine strap must have a metal-to-metal connection with the single release common to the lap belt and shoulder harness.
- b. A 6-point system – consists of a 76 mm (3 inch) wide lap belt, approximately 76 mm (3 inch) wide shoulder straps and two (2) approximately 51 mm (2 inch) wide leg or anti-submarine straps.

- c. A 7-point system – system is the same as the 6-point except it has three (3) anti-submarine straps, two (2) from the 6-point system and one (1) from the 5-point system.
Note: 6 and 7-point harnesses to FIA specification 8853/98 and SFI Specification 16.5 with approximately 51 mm (2 inch) lap belts are acceptable.
- d. An “upright driving position” is defined as one with a seat back angled at thirty degrees (30°) or less from the vertical as measured along the line joining the two 200 mm circles of the template of the 95th percentile male as defined in Rule B.3.9.3 and positioned per B.3.9.4.
- e. A “reclined driving position” is defined as one with a seat back angled at more than thirty degrees (30°) from the vertical as measured along the line joining the two 200 mm circles of the template of the 95th percentile male as defined in Rule B.3.9.3 and positioned per B.3.9.4.
- f. The “chest-groin line” is the straight line that in side view follows the line of the shoulder belts from the chest to the release buckle.

B5.1.2 Harness Requirements

All drivers must use a 5, 6 or 7 point restraint harness meeting the following specifications:

- a. All driver restraint systems must meet SFI Specification 16.1, SFI Specification 16.5, or FIA specification 8853/98.
- b. The belts must bear the appropriate dated labels.
- c. The material of all straps must be in perfect condition.
- d. There must be a single release common to the lap belt and shoulder harness using a metal-to-metal quick release type latch.
- e. To accommodate drivers of differing builds, all lap belts must have a “quick adjuster” feature. Lap belts with “pull-up” adjusters are recommended over “pull-down” adjusters.
- f. Cars with a “reclined driving position” (see B.5.1.1.e above) must have either a 6 point or 7-point harness, AND have either anti-submarine belts with “quick adjusters” or have two (2) sets of anti-submarine belts installed.
- g. The shoulder harness must be the over-the-shoulder type. Only separate shoulder straps are permitted (i.e. “y”-type shoulder straps are not allowed). The “H”-type configuration is allowed.
- h. It is mandatory that the shoulder harness, where it passes over the shoulders, be 76 mm (3 inch) wide, except as noted below. The shoulder harness straps must be threaded through the three bar adjusters in accordance with manufacturer’s instructions.
- i. When the HANS device is used by the driver, FIA certified 51 mm (2 inch) wide shoulder harnesses are allowed. Should a driver, at anytime not utilize the HANS device, then 76 mm (3 inch) wide shoulder harnesses are required.

B5.1.3 Harness Replacement

SFI spec harnesses must be replaced following December 31st of the 2nd year after the date of manufacture as indicated by the label. FIA spec harnesses must be replaced following December 31st of the year marked on the label. (Note: FIA belts are normally certified for five (5) years from the date of manufacture.)

B5.1.4 The restraint system must be worn tightly at all times.

5.2 Belt, Strap and Harness Installation - General

B5.2.1 The lap belt, shoulder harness and anti-submarine strap(s) must be securely mounted to the Primary Structure. Such structure and any guide or support for the belts must meet the minimum requirements of B.3.3.1.

B5.2.2 The tab to which any harness is attached must have:

- a. A minimum cross sectional area of 60 sq. mm (0.093 sq. in) of steel to be sheared or failed in tension at any point of the tab, and
- b. A minimum thickness of 1.6 mm (0.063 inch).
- c. *Where lap belts and anti-submarine belts use the same attachment point, a minimum cross sectional area of 90 sq. mm (0.140 sq in) of steel to be sheared if failed in tension at any point of the tab.*

Note: Double shear mounting is preferred.

- B.5.2.3 Harnesses, belts and straps must not pass through a firewall, i.e. all harness attachment points must be on the driver's side of any firewall.
- B.5.2.4 The attachment of the Driver's Restraint System to a monocoque structure requires an approved Structural Equivalency Form per Rule B.3.8.
- B.5.2.5 The restraint system installation is subject to approval of the Chief Technical Inspector.

B5.3 Lap Belt Mounting

- B5.3.1 The lap belt must pass around the pelvic area below the Anterior Superior Iliac Spines (the hip bones).
- B5.3.2 The lap belts should not be routed over the sides of the seat. The lap belts should come through the seat at the bottom of the sides of the seat to maximize the wrap of the pelvic surface and continue in a straight line to the anchorage point.
- B5.3.3 Where the belts or harness pass through a hole in the seat, the seat must be rolled or grommeted to prevent chafing of the belts.
- B5.3.4 To fit drivers of differing statures correctly, in side view, the lap belt must be capable of pivoting freely by using either a shouldered bolt or an eye bolt attachment, i.e. mounting lap belts by wrapping them around frame tubes is no longer acceptable.
- B5.3.5 With an "upright driving position", in side view the lap belt must be at an angle of between forty-five degrees (45°) and sixty-five degrees (65°) to the horizontal. This means that the centerline of the lap belt at the seat bottom should be between 0 – 76 mm (0 – 3 inches) forward of the seat back to seat bottom junction. (See Figure 10).
- B5.3.6 With a "reclined driving position", in side view the lap belt must be between an angle of sixty degrees (60°) and eighty degrees (80°) to the horizontal.

B5.4 Shoulder Harness

- B5.4.1 The shoulder harness must be mounted behind the driver to structure that meets the requirements of 3.3.1. However, it cannot be mounted to the Main Roll Hoop Bracing or attendant structure without additional bracing to prevent loads being transferred into the Main Hoop Bracing.
- B5.4.2 If the harness is mounted to a tube that is not straight, the joints between this tube and the structure to which it is mounted must be reinforced in side view by gussets or triangulation tubes to prevent torsional rotation of the harness mounting tube.
- B5.4.3 The shoulder harness mounting points must be between 178 mm (7 inches) and 229 mm (9 inches) apart. (See Figure 11).

B5.4.4 From the driver's shoulders rearwards to the mounting point or structural guide, the shoulder harness must be between ten degrees (10°) above the horizontal and twenty degrees (20°) below the horizontal. (See Figure 12).

B5.5 Anti-Submarine Belt Mounting

B5.5.1 The anti-submarine belt of a 5 point harness should be mounted in line with, or angled slightly forward (up to twenty degrees (20°)) of, the driver's chest-groin line.

B5.5.2 The anti-submarine belts of a 6 point harness should be mounted either:

- a. With the belts going vertically down from the groin, or angled up to twenty degrees (20°) rearwards. The anchorage points should be approximately 100 mm (4 inches) apart. Or
- b. With the anchorage points on the Primary Structure at or near the lap belt anchorages, the driver sitting on the anti-submarine belts, and the belts coming up around the groin to the release buckle.

5.6 Head Restraint

B5.6.1 A head restraint must be provided on the car to limit the rearward motion of the driver's head.

B5.6.2 The restraint must:

- Be vertical or near vertical in side view.
- Be padded with an energy absorbing material such as Ethafoam® or Ensolite® with a minimum thickness of 38 mm (1.5 inches).
- Be located so that:
 - It is no more than 25 mm (1 inch) away from the back of the driver's helmet in the uncompressed state, *with the driver in his/her normal driving position.*
 - The contact point of the back of the driver's helmet on the head restraint is no less than 50 mm (2 inch) from any edge of the head restraint.

B5.6.3 The restraint, its attachment and mounting must be strong enough to withstand a force of 890 Newtons (200 lbs. force) applied in a rearward direction.

Notes: (1) The head restraint must meet the above requirements for all drivers.

(2) Head restraints may be changed to accommodate different drivers (See B.1.2.2.d)

B5.7 Roll Bar Padding

Any portion of the roll bar, roll bar bracing or frame which might be contacted by the driver's helmet must be covered with a minimum thickness of 12 mm (0.5 inch) of padding which meets SFI spec 45.1 or FIA 8857-2001.

B5.8 Driver's Leg Protection

B5.8.1 To keep the driver's legs away from moving or sharp components, all moving suspension and steering components, and other sharp edges inside the cockpit between the front roll hoop and a vertical plane 100 mm (4 inches) rearward of the pedals, must be shielded with a shield made of a solid material. Moving components include, but are not limited to springs, shock absorbers, rocker arms, anti-roll/sway bars, steering racks and steering column CV joints.

B5.8.2 Covers over suspension and steering components must be removable to allow inspection of the mounting points.

ARTICLE 6: GENERAL CHASSIS RULES**B6.1 Suspension**

- B6.1.1 The car must be equipped with a fully operational suspension system with shock absorbers, front and rear, with usable wheel travel of at least 50.8 mm (2 inches), 25.4 mm (1 inch) jounce and 25.4 mm (1 inch) rebound, with driver seated. The judges reserve the right to disqualify cars which do not represent a serious attempt at an operational suspension system or which demonstrate handling inappropriate for an autocross circuit.
- B6.1.2 All suspension mounting points must be visible at Technical Inspection, either by direct view or by removing any covers.

B6.2 Ground Clearance

There is no minimum ground clearance requirement. However, teams are reminded that under Rule D1.1.2 any vehicle condition which could, among other things, "... compromise the track surface" is a valid reason for exclusion from an event. Any vehicle contact that creates a hazardous condition or which could damage either the track surface or the timing system is cause for declaring a vehicle DQ.

B6.3 Wheels

- B6.3.1 The wheels of the car must be 203.2 mm (8.0 inches) or more in diameter.
- B6.3.2 Any wheel mounting system that uses a single retaining nut must incorporate a device to retain the nut and the wheel in the event that the nut loosens. *A second nut ("jam nut") does not meet these requirements.*
- B6.3.3 *Standard wheel lug bolts are considered engineered fasteners and any modification will be subject to extra scrutiny during technical inspection. Teams using modified lug bolts or custom designs will be required to provide proof that good engineering practices have been followed in their design.*
- B6.3.4 *Aluminum wheel nuts may be used, but they must be hard anodized and in pristine condition.*

B6.4 Tires

- B6.4.1 Vehicles may have two types of tires as follows:
- Dry Tires – The tires on the vehicle when it is presented for technical inspection are defined as its "Dry Tires". The dry tires may be any size or type. They may be slicks or treaded.
 - Rain Tires – Rain tires may be any size or type of treaded or grooved tire provided:
 1. The tread pattern or grooves were molded in by the tire manufacturer, or were cut by the tire manufacturer or his appointed agent. Any grooves that have been cut must have documentary proof that it was done in accordance with these rules.
 2. There is a minimum tread depth of 2.4 mms (3/32 inch).

Note: Hand cutting, grooving or modification of the tires by the teams is specifically prohibited.

- B6.4.2 Within each tire set, the tire compound or size, or wheel type or size may not be changed after static judging has begun. Tire warmers are not allowed. No traction enhancers may be applied to the tires after the static judging has begun.

B6.5 Steering

- B6.5.1 *The steering wheel must be mechanically connected to the wheels, i.e. “steer-by-wire” is prohibited.*
- B6.5.2 The steering system must have positive steering stops that prevent the steering linkages from locking up (the inversion of a four-bar linkage at one of the pivots). The stops may be placed on the uprights or on the rack and must prevent the tires from contacting suspension, body, or frame members during the track events.
- B6.5.3 Allowable steering system free play is limited to seven degrees (7°) total measured at the steering wheel.
- B6.5.4 The steering wheel must be attached to the column with a quick disconnect. The driver must be able to operate the quick disconnect while in the normal driving position with gloves on.
- B6.5.5 The steering wheel must have a continuous perimeter that is near circular or near oval, i.e. the outer perimeter profile can have some straight sections, but no concave sections. “H”, “Figure 8”, or cutout wheels are not allowed.
- B6.5.6 In any angular position, the top of the steering wheel must be no higher than the top-most surface of the Front Hoop. See Figure 3.

B6.6 Jacking Point

- B6.6.1 A jacking point, which is capable of supporting the car’s weight and of engaging the organizers’ “quick jacks”, must be provided at the very rear of the car.
- B6.6.2 The jacking point is required to be:
 - Visible to a person standing 1 meter (3 feet) behind the car.
 - Painted orange.
 - Oriented horizontally and perpendicular to the centerline of the car
 - Made from round, 25 – 29 mm (1 – 1 1/8 inch) O.D. aluminum or steel tube
 - A minimum of 300 mm (12 inches) long
 - Exposed around the lower 180 degrees (180°) of its circumference over a minimum length of 280 mm (11 in)
 - The height of the tube is required to be such that:
 - There is a minimum of 75 mm (3 in) clearance from the bottom of the tube to the ground measured at tech inspection.
 - With the bottom of the tube 200 mm (7.9 in) above ground, the wheels do not touch the ground when they are in full rebound.

***Comment on Disabled Cars** – The organizers and the Rules Committee remind teams that cars disabled on course must be removed as quickly as possible. A variety of tools may be used to move disabled cars including quick jacks, dollies of different types, tow ropes and occasionally even boards. We expect cars to be strong enough to be easily moved without damage. Speed is important in clearing the course and although the course crew exercises due care, parts of a vehicle can be damaged during removal. The organizers are not responsible for damage that occurs when moving disabled vehicles. Removal/recovery workers will jack, lift or tow the car at whatever points they find easiest to access. Accordingly, we advise teams to consider the strength and location of all obvious jacking, lifting and towing points during the design process.*

B6.7 Rollover Stability

- B6.7.1 The track and center of gravity of the car must combine to provide adequate rollover stability.
- B6.7.2 Rollover stability will be evaluated on a tilt table using a pass/fail test. The vehicle must not roll when tilted at an angle of sixty degrees (60°) to the horizontal in either direction, corresponding to 1.7 G's. The tilt test will be conducted with the tallest driver in the normal driving position.

ARTICLE 7: BRAKE SYSTEM

B7.1 Brake System - General

The car must be equipped with a braking system that acts on all four wheels and is operated by a single control.

- B7.1.1 It must have two independent hydraulic circuits such that in the case of a leak or failure at any point in the system, effective braking power is maintained on at least two wheels. Each hydraulic circuit must have its own fluid reserve, either by the use of separate reservoirs or by the use of a dammed, OEM-style reservoir.
- B7.1.2 A single brake acting on a limited-slip differential is acceptable.
- B7.1.3 The brake system must be capable of locking all four (4) wheels during the test specified below.
- B7.1.4 “Brake-by-wire” systems are prohibited.
- B7.1.5 Unarmored plastic brake lines are prohibited.
- B7.1.6 The braking systems must be protected with scatter shields from failure of the drive train (see B.8.13) or from minor collisions.
- B7.1.7 In side view no portion of the brake system that is mounted on the sprung part of the car can project below the lower surface of the frame or the monocoque, whichever is applicable.
- B7.1.8 *The brake pedal shall be designed to withstand a force of 2000 N without any failure of the brake system or pedal box. This may be tested by pressing the pedal with the maximum force that can be exerted by any official when seated normally.*
- B7.1.9 *The brake pedal must be fabricated from steel or aluminum or machined from steel, aluminum or titanium.*

B7.2 Brake Test

The brake system will be dynamically tested and must demonstrate the capability of locking all four (4) wheels and stopping the vehicle in a straight line at the end of an acceleration run specified by the brake inspectors.

B7.3 Brake Over-Travel Switch

- B7.3.1 A brake pedal over-travel switch must be installed on the car. This switch must be installed so that in the event of brake system failure such that the brake pedal over travels, the switch will be activated and will stop the engine from running. This switch must kill the ignition and cut the power to any electrical fuel pumps.

- B7.3.2 Repeated actuation of the switch must not restore power to these components, and it must be designed so that the driver cannot reset it.
- B7.3.3 The switch must be implemented with analog components, and not through recourse to programmable logic controllers, engine control units, or similar functioning digital controllers.
- B7.4 Brake Light**
- B7.4.1 The car must be equipped with a red brake light of at least 15 watts, or equivalent, clearly visible from the rear. If an LED brake light is used, it must be clearly visible in very bright sunlight.
- B7.4.2 This light must be mounted between the wheel centerline and driver's shoulder level vertically and approximately on vehicle centerline laterally.

ARTICLE 8: POWERTRAIN

B8.1 Engine Limitation

- B8.1.1 *The engine(s) used to power the car must be a piston engine(s) using a four-stroke primary heat cycle with a displacement not exceeding 610 cc per cycle. Hybrid powertrains, such as those using electric motors running off stored energy, are prohibited.*

Note: All waste/rejected heat from the primary heat cycle may be used. The method of conversion is not limited to the four-stroke cycle.

- B8.1.2 The engine can be modified within the restrictions of the rules.
- B8.1.3 If more than one engine is used, the total displacement cannot exceed 610 cc and the air for all engines must pass through a single air intake restrictor (see B.8.6, "Intake System Restrictor.")

B8.2 Engine Inspection

The organizer will measure or tear down a substantial number of engines to confirm conformance to the rules. The initial measurement will be made externally with a measurement accuracy of one (1) percent. When installed to and coaxially with spark plug hole, the measurement tool has dimensions of 381 mm (15 inches) long and 30 mm (1.2 inches) diameter. Teams may choose to design in access space for this tool above each spark plug hole to reduce time should their vehicle be inspected.

B8.3 Starter

Each car must be equipped with an on-board starter which, during the competition, must be used to start the car at all times. Push starts, or the use of a remote starter, are prohibited.

B8.4 Air Intake System

B8.4.1 Air Intake System Location

All parts of the engine air and fuel control systems (including the throttle or carburetor, and the complete air intake system, including the air cleaner and any air boxes) must lie within the surface defined by the top of the roll bar and the outside edge of the four tires. (See Figure 13).

- B8.4.2 Any portion of the air intake system that is less than 350 mm (13.8 inches) above the ground must be shielded from side or rear impact collisions by structure built to Rule B.3.24 or B.3.31 as applicable.

- B8.4.3 Intake Manifold – The intake manifold must be securely attached to the engine block or cylinder head with brackets and mechanical fasteners. This precludes the use of hose clamps, plastic ties, or safety wires. The use of rubber bushings or hose is acceptable for creating and sealing air passages, but is not considered a structural attachment.
- B8.4.4 *Intake systems with significant mass or cantilever from the cylinder head must be supported to prevent stress to the intake system. Supports to the engine must be rigid. Supports to the frame or chassis must incorporate some isolation to allow for engine movement and chassis flex.*

B8.5 Throttle and Throttle Actuation

B8.5.1 Carburetor/Throttle Body

The car must be equipped with a carburetor or throttle body. The carburetor or throttle body may be of any size or design.

B8.5.2 Throttle Actuation

The throttle must be actuated mechanically, i.e. via a cable or a rod system. The use of electronic throttle control (ETC) or “drive-by-wire” is prohibited.

- B8.5.3 The throttle cable or rod must have smooth operation, and must not have the possibility of binding or sticking.

- B8.5.4 The throttle actuation system must use at least two (2) return springs located at the throttle body, so that the failure of any component of the throttle system will not prevent the throttle returning to the closed position.

Note: Throttle Position Sensors (TPS) are NOT acceptable as return springs.

- B8.5.5 Throttle cables must be at least 50.8 mm (2 inches) from any exhaust system component and out of the exhaust stream.

- B8.5.6 A positive pedal stop must be incorporated on the throttle pedal to prevent over stressing the throttle cable or actuation system.

B8.6 Intake System Restrictor

- B8.6.1 In order to limit the power capability from the engine, a single circular restrictor must be placed in the intake system between the throttle and the engine and all engine airflow must pass through the restrictor.

- B8.6.2 Any device that has the ability to throttle the engine downstream of the restrictor is prohibited.

- B8.6.3 The maximum restrictor diameters are:
- Gasoline fueled cars - 20.0 mm (0.7874 inch)
 - E-85 fueled cars – 19.0 mm (0.7480 inch)

- B8.6.4 The restrictor must be located to facilitate measurement during the inspection process.

- B8.6.5 The circular restricting cross section may NOT be movable or flexible in any way, e.g. the restrictor may not be part of the movable portion of a barrel throttle body.

- B8.6.6 If more than one engine is used, the intake air for all engines must pass through the one restrictor.

B8.7 Turbochargers & Superchargers

- B8.7.1 Turbochargers or superchargers are allowed if the competition team designs the application. Engines that have been designed for and originally come equipped with a turbocharger are not allowed to compete with the turbo installed.
- B8.7.2 The restrictor must be placed upstream of the compressor but after the carburetor or throttle valve. Thus, the only sequence allowed is throttle, restrictor, compressor, engine.
- B8.7.3 The intake air may be cooled with an intercooler (a charge air cooler). Only ambient air may be used to remove heat from the intercooler system. Air-to-air and water-to air intercoolers are permitted. The coolant of a water-to-air intercooler system must comply with Rule B.8.10.

B8.8 Fuel Lines, Attachment and Protection

- B8.8.1 Plastic fuel lines between the fuel tank and the engine (supply and return) are prohibited.
- B8.8.2 If rubber fuel line or hose is used, the components over which the hose is clamped must have annular bulb or barbed fittings to retain the hose. Also, clamps specifically designed for fuel lines must be used. These clamps have three (3) important features, (i) a full 360 degree (360°) wrap, (ii) a nut and bolt system for tightening, and (iii) rolled edges to prevent the clamp cutting into the hose. Worm-gear type hose clamps are not approved for use on any fuel line.
- B8.8.3 Fuel lines must be securely attached to the vehicle and/or engine.
- B8.8.4 All fuel lines must be shielded from possible rotating equipment failure or collision damage.

B8.9 Fuel Injection System Requirements

B8.9.1 Low Pressure Injection (LPI)

Low pressure fuel injection systems are those functioning at a pressure below 10 Bar (145 psi). Most Port Fuel Injected (PFI) fuel systems are low pressure.

(A) Fuel Lines – *On low pressure fuel injected systems, any flexible fuel lines must be either (i) metal braided hose with either crimped-on or reusable, threaded fittings, or (ii) reinforced rubber hose with some form of abrasion resistant protection with fuel line clamps per B8.8.2 . **Note: Hose clamps over metal braided hose will not be accepted.***

(B) Fuel Rail – *The fuel rail must be securely attached to the engine cylinder block, cylinder head, or intake manifold with mechanical fasteners. This precludes the use of hose clamps, plastic ties, or safety wire.*

(C) Intake Manifold – *On engines with port fuel injection, the intake manifold must be securely attached to the engine block or cylinder head.*

B8.9.2 High Pressure Injection (HPI) / Direct Injection (DI)

High pressure fuel systems are those functioning at 10 Bar (145 psi) pressure or above. Direct injection fuel systems are those where the injection occurs directly into the combustion system. DI systems often utilize a low pressure electric fuel pump and high pressure mechanical “boost” pump driven off the engine. The high pressure lines are those between the boost pump and injectors, and the low pressure lines lead from the electric supply pump up to the boost pump.

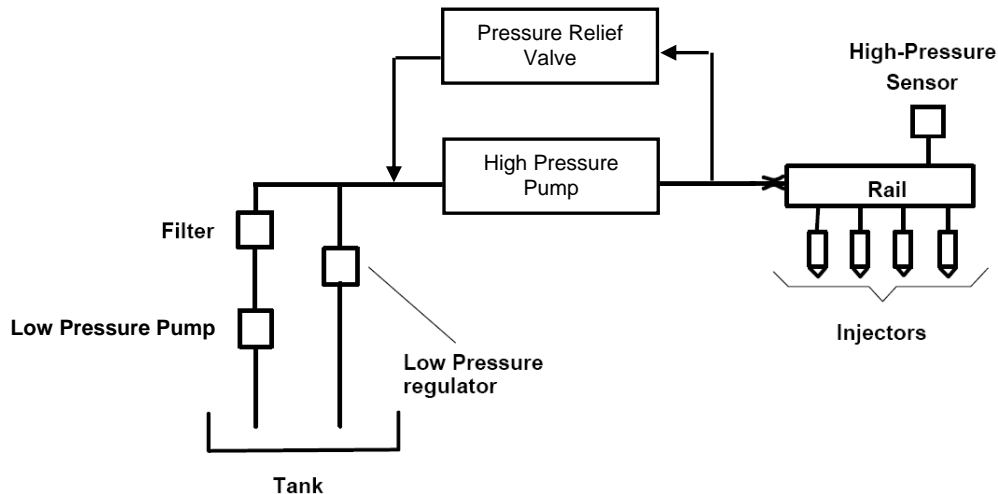

(A) High Pressure Fuel Lines – All high pressure fuel lines, normally those downstream of the high pressure pump on Direct Injection systems, must be stainless steel rigid line or Aeroquip FC807 smooth bore PTFE hose with stainless steel reinforcement and visible Nomex tracer yarn. Equivalent products may be used with prior Rules Committee approval. Use of elastomeric seals is prohibited. Lines must be rigidly connected every 100mm by mechanical fasteners to structural engine components such as cylinder heads or block.

(B) Low Pressure Fuel Lines – Low pressure lines, normally those upstream of the high pressure pump, that are flexible must be either (i) metal braided hose with either crimped-on or reusable, threaded fittings, or (ii) reinforced rubber hose with some form of abrasion resistant protection with fuel line clamps per B8.8.2. **Note: Hose clamps over metal braided hose will not be accepted.**

(C) Fuel Rail – The fuel rail must be securely attached to the engine cylinder head with mechanical fasteners. This precludes the use of hose clamps, plastic ties, or safety wire. The fastening method must be sufficient to hold the fuel rail in place with the maximum regulated pressure acting on the injector internals and neglecting any assistance from in-cylinder pressure acting on the injector tip.

(D) High Pressure Fuel Pump – The fuel pump must be rigidly mounted to structural engine components such as the cylinder head or engine block.

(E) Pressure Regulator – A fuel pressure regulator must be fitted between the high and low pressure sides of the fuel system in parallel with the DI boost pump. The external regulator must be used even if the DI boost pump comes equipped with an internal regulator.

(F) Required Test – Prior to the tilt test specified in B9.9, engines fitted with mechanically actuated fuel pumps must be run to fill and pressure the system downstream of the high pressure pump.

B8.10 Coolant Fluid Limitations

Water-cooled engines must only use plain water. Glycol-based antifreeze, “water wetter”, water pump lubricants of any kind, or any other additives are strictly prohibited.

B8.11 System Sealing

B8.11.1 The engine and transmission must be sealed to prevent leakage.

- B8.11.2 Separate catch cans must be employed to retain fluids from any vents for the coolant system or the crankcase or engine lubrication system. Each catch-can must have a minimum volume of ten (10) percent of the fluid being contained or 0.9 liter (one U.S. quart) whichever is greater.
- B8.11.3 Catch cans must be capable of containing boiling water without deformation, and be located rearwards of the firewall below driver's shoulder level, and be positively retained, i.e. no tie-wraps or tape.
- B8.11.4 Any catch can on the cooling system must vent through a hose with a minimum internal diameter of 3 mm (1/8 inch) down to the bottom levels of the Frame.
- B8.11.5 Any crankcase or engine lubrication vent lines routed to the intake system must be connected upstream of the intake system restrictor.
- B8.11.6 *Crankcase breathers that pass through the oil catch tank(s) to exhaust systems, or vacuum devices that connect directly to the exhaust system, are prohibited.*

B8.12 Transmission and Drive

Any transmission and drivetrain may be used.

B8.13 Drive Train Shields and Guards

B8.13.1 Exposed high-speed final drivetrain equipment such as Continuously Variable Transmissions (CVTs), sprockets, gears, pulleys, torque converters, clutches, belt drives and clutch drives, must be fitted with scatter shields in case of failure. The final drivetrain shield must cover the chain or belt from the drive sprocket to the driven sprocket/chain wheel/belt or pulley. The final drivetrain shield must end parallel to the lowest point of the chain wheel/belt/pulley. (See figure 2) Body panels or other existing covers are not acceptable unless constructed from approved materials per B8.13.3 or B8.13.4.

Comment: Scatter shields are intended to contain drivetrain parts which might separate from the car.

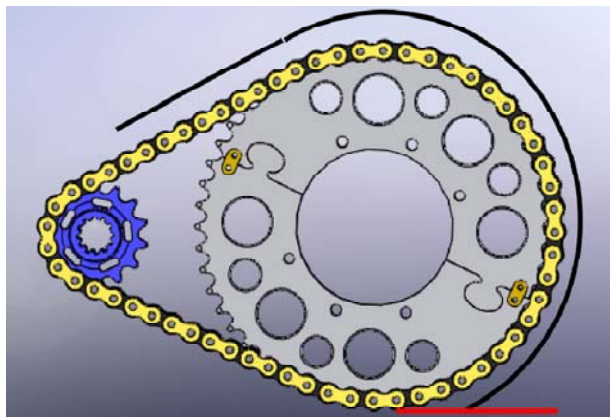

Fig. 2. Final Drive scatter shield example.

B8.13.2 Perforated material may not be used for the construction of scatter shields.

B8.13.3 Chain Drive - Scatter shields for chains must be made of at least 2.66 mm (0.105 inch) steel (no alternatives are allowed), and have a minimum width equal to three (3) times the width of the chain. The guard must be centered on the center line of the chain and remain aligned with the chain under all conditions.

- B8.13.4 *Non-metallic Belt Drive - Scatter shields for belts must be made from at least 3.0 mm (0.120 inch) Aluminum Alloy 6061-T6, and have a minimum width that is equal to 1.7 times the width of the belt. The guard must be centered on the center line of the belt and remain aligned with the belt under all conditions.*
- B8.13.5 Attachment Fasteners - All fasteners attaching scatter shields and guards must be a minimum 6mm grade M8, or stronger (1/4 inch SAE grade 5).
- B8.13.6 *Finger Guards – Finger guards are required to cover any drivetrain parts that spin while the car is stationary with the engine running. Finger guards may be made of lighter material, sufficient to resist finger forces. Mesh or perforated material may be used but must prevent the passage of a 12 mm (1/2 inch) diameter object through the guard.*

Comment: Finger guards are intended to prevent finger intrusion into rotating equipment while the vehicle is at rest.

ARTICLE 9: FUEL AND FUEL SYSTEM

B9.1 Fuel

The basic fuel available at competitions in the Formula SAE Series is unleaded gasoline with an octane rating of 93 (R+M)/2 (approximately 98 RON). However, the basic fuel may be changed at the discretion of the organizing body. Other fuels may be available at the discretion of the organizing body.

- B9.1.1 Unless otherwise announced by the individual organizing body, the fuel at competitions in the Formula SAE Series will be provided by the organizer.
- B9.1.2 During all performance events the cars must be operated with the fuels provided by the organizer at the competition.
- B9.1.3 Nothing may be added to the provided fuels. This prohibition includes nitrous oxide or any other oxidizing agent.

Note 1: Teams are advised that the fuel supplied in the United States is subject to various federal and state regulations and may contain up to ten percent (10%) ethanol. The exact chemical composition and physical characteristics of the available fuel may not be known prior to the competition.

Note 2: The fuels provided at Formula SAE Michigan are expected to be 93 and 100 octane [(R+M)/2] gasoline and E-85. The fuels provided at Formula SAE California are expected to be 91 and 97 octane [(R+M)/2] gasoline and E-85. This is subject to change.

Consult the individual competition websites for fuel types and other information.

B9.2 Fuel Additives - Prohibited

- B9.2.1 No agents other than fuel (gasoline or E85), and air may be induced into the combustion chamber. Non-adherence to this rule will be reason for disqualification.
- B9.2.2 Officials have the right to inspect the oil.

B9.3 Fuel Temperature Changes - Prohibited

The temperature of fuel introduced into the fuel system may not be changed with the intent to improve calculated fuel economy.

B9.4 Fuel Tanks

B9.4.1 The fuel tank is defined as that part of the fuel containment device that is in contact with the fuel. It may be made of a rigid material or a flexible material.

B9.4.2 Fuel tanks made of a rigid material cannot be used to carry structural loads, e.g. from roll hoops, suspension, engine or gearbox mounts, and must be securely attached to the vehicle structure with mountings that allow some flexibility such that chassis flex cannot unintentionally load the fuel tank.

B9.4.3 Any fuel tank that is made from a flexible material, for example a bladder fuel cell or a bag tank, must be enclosed within a rigid fuel tank container which is securely attached to the vehicle structure. Fuel tank containers (containing a bladder fuel cell or bag tank) may be load carrying.

B9.4.4 Any size fuel tank may be used.

B9.4.5 The fuel system must have a provision for emptying the fuel tank if required.

B9.5 Fuel System Location Requirements

B9.5.1 All parts of the fuel storage and supply system must lie within the surface defined by the top of the roll bar and the outside edge of the four tires. (See Figure 13).

B9.5.2 All fuel tanks must be shielded from side or rear impact collisions. Any fuel tank which is located outside the Side Impact Structure required by *B.3.24* or *B.3.31* must be shielded by structure built to *B.3.2*, or *B.3.31*.

B9.5.3 A firewall must be incorporated to separate the fuel tank from the driver, per Rule B.4.5.

B9.6 Fuel Tank Filler Neck & Sight Tube

B9.6.1 All fuel tanks must have a filler neck:

- (a) at least 38 mm (1.5 inches) diameter,
- (b) at least 125 mm (4.9 inches) vertical height and
- (c) angled at no more than forty-five degrees (45°) from the vertical.

B9.6.2 The 125 mm of vertical height must be above the top level of the tank, and must be accompanied by a clear fuel resistant sight tube for reading the fuel level. (Figure 14).

B9.6.3 The sight tube must have at least 75 mm (3 inches) of vertical height and a minimum inside diameter of 6 mm (0.25 inches).

B9.6.4 The sight tube must not run below the top surface of the fuel tank.

B9.6.5 A clear filler tube may be used as a sight tube, subject to approval by the Rules Committee or technical inspectors at the event.

B9.6.6 A permanent, non-moveable fuel level line must be located between 12.7 mm and 25.4 mm (0.5 inch and 1 inch) below the top of the sight tube. This line will be used as the fill line for the Tilt Test (Rule B.9.9), and before and after the Endurance Test to measure the amount of fuel used during the Endurance Event.

B9.6.7 The sight tube and fuel level line must be clearly visible to an individual filling the tank.

B9.7 Tank Filling Requirement

B.9.7.1 The fuel tank must be capable of being filled to capacity without manipulating the tank or the vehicle in any manner. During fueling or refueling the vehicle may only be touched by the fuel crew and officials. The tank will be filled to the fill line, or if a filling system is used, to the automatic stop point. If, for any reason, the fuel level changes after the team has moved the vehicle, then no additional fuel will be added.

B9.7.2 The fuel system must be designed such that the spillage during refueling cannot contact the driver position, exhaust system, hot engine parts, or the ignition system.

B9.7.3 Belly pans must be vented to prevent accumulation of fuel.

B9.8 Venting Systems

B9.8.1 The fuel tank and carburetor venting systems must be designed such that fuel cannot spill during hard cornering or acceleration. This is a concern since motorcycle carburetors normally are not designed for lateral accelerations.

B9.8.2 All fuel vent lines must be equipped with a check valve to prevent fuel leakage when the tank is inverted. All fuel vent lines must exit outside the bodywork.

B9.9 Fuel System Integrity – Tilt Test

B9.9.1 Tilt Test - Fuel and Fluids

During technical inspection, the car must be capable of being tilted to a forty-five degree (45°) angle without leaking fuel or fluid of any type.

B9.9.2 The tilt test will be conducted with the vehicle containing the maximum amount of fluids it will carry during any test or event.

ARTICLE 10: EXHAUST SYSTEM AND NOISE CONTROL

B10.1 Exhaust System General

B10.1.1 Exhaust Outlet

The exhaust must be routed so that the driver is not subjected to fumes at any speed considering the draft of the car.

B10.1.2 The exhaust outlet(s) must not extend more than 45 cm (17.7 inches) behind the centerline of the rear axle, and shall be no more than 60 cm (23.6 inches) above the ground.

B10.1.3 Any exhaust components (headers, mufflers, etc.) that protrude from the side of the body in front of the main roll hoop must be shielded to prevent contact by persons approaching the car or a driver exiting the car.

B10.2 Noise Measuring Procedure

B10.2.1 The sound level will be measured during a static test. Measurements will be made with a free-field microphone placed free from obstructions at the exhaust outlet level, 0.5 m (19.68 inches) from the end of the exhaust outlet, at an angle of forty-five degrees (45°) with the outlet in the horizontal plane. The test will be run with the gearbox in neutral at the engine speed defined below. Where more than

one exhaust outlet is present, the test will be repeated for each exhaust and the highest reading will be used.

B10.2.2 The car must be compliant at all engine speeds up to the test speed defined below.

B10.2.3 If the exhaust has any form of movable tuning or throttling device or system, it must be compliant with the device or system in all positions. The position of the device must be visible to the officials for the noise test and must be manually operable by the officials during the noise test.

B10.2.4 Test Speeds

The test speed for a given engine will be the engine speed that corresponds to an average piston speed of 914.4 m/min (3,000 ft/min) for automotive or motorcycle engines, and 731.5 m/min (2,400 ft/min) for “industrial engines”. The calculated speed will be rounded to the nearest 500 rpm. The test speeds for typical engines will be published by the organizers.

An “industrial engine” is defined as an engine which, according to the manufacturers’ specifications and without the required restrictor, is not capable of producing more than 5 hp per 100cc. To have an engine classified as “an industrial engine”, approval must be obtained from organizers prior to the Competition.

B10.3 Maximum Sound Level

The maximum permitted sound level is 110 dBA, fast weighting.

B10.4 Noise Level Re-testing

At the option of the officials, noise can be measured at any time during the competition. If a car fails the noise test, it will be withheld from the competition until it has been modified and re-passes the noise test.

ARTICLE 11: ELECTRICAL SYSTEM

B11.1 Master Switches

B11.1.1 The vehicle must be equipped with two (2) master switches. Actuating either switch must stop the engine.

B11.1.2 The international electrical symbol consisting of a red spark on a white-edged blue triangle must be affixed in close proximity to each switch.

Note: Teams are reminded that any alternator field wire must also be disabled by each master switch to prevent any possible feedback through the field coil circuit.

B11.2 Primary Master Switch

B11.2.1 The primary master switch must:

- a. Be located on the (driver’s) right side of the vehicle, in proximity to the Main Hoop, at shoulder height and be easily actuated from outside the car.
- b. Disable power to ALL electrical circuits, including the battery, alternator, lights, fuel pump(s), ignition and electrical controls.
- c. All battery current must flow through this switch.
- d. Be of a rotary type and must be direct acting, i.e. it cannot act through a relay.

An example of a typical switch that meets these requirements is shown below.



B11.2.2 The “OFF” position of the primary master switch must be clearly marked.

B11.3 Cockpit-mounted Master Switch

B11.3.1 The cockpit-mounted master switch:

- a. Must be located to provide easy actuation by the driver in an emergency or panic situation.
- b. Must be located within easy reach of the belted-in driver, alongside the steering wheel, and unobstructed by the steering wheel or any other part of the car. It is suggested that it be placed on the same side of the steering wheel as the shifter mechanism.
- c. Must be a push/pull Emergency switch. The switch must be installed such that:
 - i. From the ON position, pushing on the switch will disable power to the ignition and all fuel pumps, and
 - ii. From the OFF position, pulling on the switch will enable power to the ignition and fuel pump(s). Switches that require a twist or twist and pull to enable power are acceptable.
- d. May act through a relay.

Examples of typical switches that meet these requirements are shown below.



B11.4 Batteries

B11.4.1 All batteries, i.e. on-board power supplies, must be attached securely to the frame.

B11.4.2 Any wet-cell battery located in the driver compartment must be enclosed in a nonconductive marine-type container or equivalent.

B11.4.3 The hot terminal must be insulated on all cars.

ARTICLE 12: AERODYNAMIC DEVICES

B12.1 Aero Dynamics and Ground Effects - General

All aerodynamic devices must satisfy the following requirements:

B12.2 Location

B12.2.1 In plan view, no part of any aerodynamic device, wing, under tray or splitter can be:

- a. Farther forward than 762 mm (30 inches) forward of the fronts of the front tires*
- b. No farther rearward than 305 mm (12 inches) rearward of the rear of the rear tires.*
- c. No wider than the outside of the front tires or rear tires measured at the height of the hubs, whichever is wider.*

B12.3 Minimum Radii of Edges of Aerodynamic Devices

B12.3.1 All wing edges including wings, end plates, Gurney flaps, wicker bills and undertrays that could contact a pedestrian must have a minimum radius of 1.5 mm (0.060 inch).

B12.4 Ground Effect Devices – No power device may be used to move or remove air from under the vehicle except fans designed exclusively for cooling. Power ground effects are prohibited.

B12.5 Driver Egress Requirements

B12.5.1 Egress from the vehicle within the time set in Rule B.4.8 “Driver Egress,” must not require any movement of the wing or wings or their mountings.

B12.5.2 The wing or wings must be mounted in such positions, and sturdily enough, that any accident is unlikely to deform the wings or their mountings in such a way to block the driver’s egress.

ARTICLE 13: COMPRESSED GAS SYSTEMS AND HIGH PRESSURE HYDRAULICS

B13.1 Compressed Gas Cylinders and Lines

Any system on the vehicle that uses a compressed gas as an actuating medium must comply with the following requirements:

- a. Working Gas-The working gas must be nonflammable, e.g. air, nitrogen, carbon dioxide.
- b. Cylinder Certification- The gas cylinder/tank must be of proprietary manufacture, designed and built for the pressure being used, certified by an accredited testing laboratory in the country of its origin, and labeled or stamped appropriately.
- c. Pressure Regulation-The pressure regulator must be mounted directly onto the gas cylinder/tank.
- d. Protection – The gas cylinder/tank and lines must be protected from rollover, collision from any direction, or damage resulting from the failure of rotating equipment.
- e. Cylinder Location- The gas cylinder/tank and the pressure regulator must be located either rearward of the Main Roll Hoop and within the envelope defined by the Main Roll Hoop and the Frame (see B3.2), or in a structural side-pod. In either case it must be protected by structure that meets the requirements of B3.24 or B3.31. It must not be located in the cockpit.
- f. Cylinder Mounting- The gas cylinder/tank must be securely mounted to the Frame, engine or transmission.
- g. Cylinder Axis- The axis of the gas cylinder/tank must not point at the driver.
- h. Insulation- The gas cylinder/tank must be insulated from any heat sources, e.g. the exhaust system.
- i. Lines and Fittings- The gas lines and fittings must be appropriate for the maximum possible operating pressure of the system.

B13.2 High Pressure Hydraulic Pumps and Lines

The driver and anyone standing outside the car must be shielded from any hydraulic pumps and lines with line pressures of 300 psi (2100 kPa) or higher. The shields must be steel or aluminum with a minimum thickness of 1 mm (0.039 inch).

Note: Brake lines are not classified as “hydraulic pump lines” and as such brake lines are excluded from B13.2

ARTICLE 14: FASTENERS**B14.1 Fastener Grade Requirements**

B14.1.1 All threaded fasteners utilized in the driver’s cell structure, and the steering, braking, driver’s harness and suspension systems must meet or exceed, SAE Grade 5, Metric Grade 8.8 and/or AN/MS specifications when a minimum size is specified elsewhere in these rules. .

B14.1.2 The use of button head cap, pan head, flat head or round head screws or bolts in critical locations is prohibited. These locations include the driver’s cell structure, and driver’s harness attachment.

Note: Hexagonal recessed drive screws or bolts (sometimes called Socket head cap screws or Allen screws/bolts) are permitted.

B14.2 Securing Fasteners

B14.2.1 All critical bolt, nuts, and other fasteners on the steering, braking, driver’s harness, and suspension must be secured from unintentional loosening by the use of positive locking mechanisms. Positive locking mechanisms include:

- Correctly installed safety wiring
- Cotter pins
- Nylon lock nuts
- Prevailing torque lock nuts

Note: Lock washers and thread locking compounds, e.g. Loctite®, DO NOT meet the positive locking requirement.

B14.2.2 There must be a minimum of two (2) full threads projecting from any lock nut.

B14.2.3 All spherical rod ends and spherical bearings on the steering or suspension must be in double shear or captured by having a screw/bolt head or washer with an O.D. that is larger than spherical bearing housing I.D.

B14.2.4 Adjustable tie-rod ends must be constrained with a jam nut to prevent loosening.

ARTICLE 15: TRANSPONDERS**B15.1 Transponders – North American FSAE Competitions**

B15.1.1 Transponders will be used as part of the timing system for the dynamic events at the North American FSAE competitions

- B15.1.2 Each team is responsible for having a functional, properly mounted transponder of the specified type on their vehicle. Vehicles without a specified transponder will not be allowed to compete in any event for which a transponder is used for timing and scoring.
- B15.1.3 All vehicles must be equipped with at least one AMB TranX260 Rechargeable or AMB TranX260 Direct Power transponder.



B15.2 Transponders – Events outside North America

Transponders may be used for timing and scoring at competitions outside North America and may be provided by the competition organizers. The transponders specified in 15.1 above for the North American FSAE competitions may or may not be compatible with the systems used for other events. Teams should check the individual competition websites for further details.

B15.3 Transponder Mounting – All Events

The transponder mounting requirements are:

- a. Orientation – The transponder must be mounted vertically and orientated so the number can be read “right-side up”.
- b. Location – The transponder must be mounted on the driver’s right side of the car forward of the front roll hoop. The transponder must be no more than 60 cm (24 in) above the track.
- c. Obstructions – There must be an open, unobstructed line between the antenna on the bottom of the transponder and the ground. Metal and carbon fiber may interrupt the transponder signal. The signal will normally transmit through fiberglass and plastic. If the signal will be obstructed by metal or carbon fiber, a 10.2 cm (4 in) diameter opening can be cut, the transponder mounted flush with the opening, and the opening covered with a material transparent to the signal.
- d. Protection – Mount the transponder where it will be protected from obstacles.

ARTICLE 16: VEHICLE IDENTIFICATION

B16.1 Car Number

B16.1.1 Each car will be assigned a number at the time of its entry into a competition.

B16.1.2 Car numbers must appear on the vehicle as follows:

Locations: In three (3) locations: the **front** and both **sides**;

- a. Height: At least 152.4 mm (6 inch) high;
- b. Font: Block numbers (i.e. sans-serif characters). Italic, outline, serif, shadow, or cursive numbers are prohibited.
- c. Stroke Width and Spacing between Numbers: At least 18 mm (3/4 inch).

- d. Color: Either white numbers on a black background or black numbers on a white background. No other color combinations will be approved.
- e. Background shape: The number background must be one of the following: round, oval, square or rectangular. There must be at least 25.4 mm (1 inch) between the edge of the numbers and the edge of the background.
- f. Clear: The numbers must not be obscured by parts of the car, e.g. wheels, side pods, exhaust system, etc.

B16.1.3 Car numbers for teams registered for North American FSAE competitions can be found on the “Registered Teams” section of the relevant Formula SAE website.

Comment: Car numbers must be quickly read by course marshals when your car is moving at speed. Make your numbers easy to see and easy to read.

Example:



B16.2 School Name

B16.2.1 Each car must clearly display the school name (or initials – if unique and generally recognized) in roman characters at least 50 mm (2 inch) high on both sides of the vehicle. The characters must be placed on a high contrast background in an easily visible location.

B16.2.2 The school name may also appear in non-roman characters, but the roman character version must be uppermost on the sides.

B16.3 SAE Logo

The SAE logo must be displayed on the front and/or both sides of the vehicle in a prominent location. SAE logo stickers will be provided to the teams on site.

B16.4 Technical Inspection Sticker Space

B16.4.1 Technical inspection stickers will be placed on the upper nose of the vehicle. Cars must have a clear and unobstructed area at least 25.4 cm wide x 20.3cm high (10” x 8”) on the upper front surface of the nose along the vehicle centerline.

B16.4.2 Vehicles that are being entered into multiple competitions in the FSAE series must allow sufficient space along the nose centerline for all inspection stickers.

ARTICLE 17: EQUIPMENT REQUIREMENTS

B17.1 Driver’s Equipment

The equipment specified below must be worn by the driver anytime he or she is in the cockpit with the engine running.

B17.2 Helmet

A well-fitting, closed face helmet that meets one of the following certifications and is labeled as such:

- Snell SA2000, SA2005, SA2010
- SFI 31.2A, SFI 31.1/2005
- FIA 8860-2004

- British Standards Institution BS 6658-85 Type A/FR rating (Types A and B are not accepted)

Open faced helmets are not approved.

All helmets to be used in the competition must be presented during Technical Inspection where approved helmets will be stickered. The organizer reserves the right to impound all non-approved helmets until the end of the competition.

B17.3 Balaclava

A balaclava which covers the driver’s head, hair and neck, made from acceptable fire resistant material as defined in B 17.12, or a full helmet skirt of acceptable fire resistant material. The balaclava requirement applies to drivers of either gender, with any hair length.

B17.4 Eye Protection

Impact Resistant goggles or helmet face shield, made from approved impact resistant materials. The face shield supplied with approved helmets (See B17.2 above) meets this requirement.

B17.5 Suit

A fire resistant one piece suit, made from a minimum of two (2) layers, which covers the body from the neck down to the ankles and the wrists. The suit must be in good condition, i.e. it must have no tears, open seams, damage or oil stains that could compromise its fire resistant capability. The suit must be certified to one of the following standards and be labeled as such:

- SFI 3-2A/5 (or higher)



- FIA Standard 1986

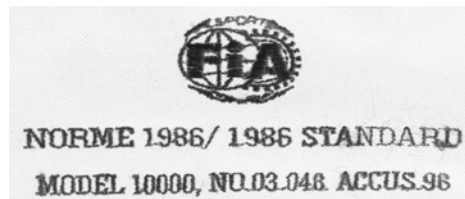

- FIA Standard 8856-2000

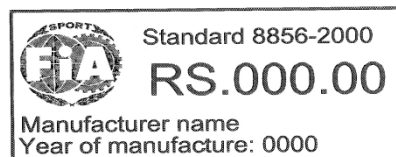

Actual size 100x40mm

B17.6 Underclothing

It is strongly recommended that all competitors wear fire resistant underwear (long pants and long sleeve t-shirt) under their approved driving suit. This fire resistant underwear should be made from acceptable fire resistant material as listed in B17.12 and should cover the driver’s body completely from neck down to ankles and wrists.

Note: If you do not wear fire resistant underwear it is strongly recommended that you wear cotton underwear (t-shirt and long underpants) under your approved driving suit.

B17.7 Socks

Fire resistant socks made from acceptable fire resistant material as defined in B 17.12, below, that cover the bare skin between the driver's suit and the boots or shoes.

B17.8 Shoes

Fire resistant shoes made from acceptable fire resistant material as defined in B17. 12. The shoes must be certified to the standard and labeled as such:

- SFI 3.3
- FIA 8856-2000

B17.9 Gloves

Fire resistant gloves made from made from acceptable fire resistant material as defined in B 17. 12. Gloves of all leather construction or fire resistant gloves constructed using leather palms with no insulating fire resisting material underneath are not acceptable.

B17.10 Arm Restraints

Arm restraints are required and must be worn such that the driver can release them and exit the vehicle unassisted regardless of the vehicle's position. Arm restraints must be commercially manufactured. Note: Arm restraints certified to SFI standard 3.3 and labeled as such meet this requirement.

B17.11 Driver's Equipment Condition

All driving apparel covered by Article 17 must be in good condition. Specifically, driving apparel must not have any tears, rips, open seams, areas of significant wear or abrasion or stains which might compromise fire resistant performance.

B17.12 Fire Resistant Material

For the purpose of this section some, but not all, of the approved fire resistant materials are: Carbon X, Indura, Nomex, Polybenzimidazole (commonly known as PBI) and Proban.

B17.13 Synthetic Material – Prohibition

T-shirts, socks or other undergarments (not to be confused with fire resistant underwear) made from nylon or any other synthetic material which will melt when exposed to high heat are not allowed.

B17.14 Fire Extinguishers

Each team must have at least two (2) 0.9 kg (2 lb.) dry chemical/dry powder or 1.75 litres Aqueous Film Forming Foam (AFFF), fire extinguishers.

B17.14.2 The following are the minimum ratings, any of which are acceptable at any Formula SAE Series event:

- USA, Canada & Brazil: 10BC or 1A 10BC
- UK, Italy & Europe: 34B or 5A 34B
- Australia: 20BE or 1A 10BE

Extinguishers of larger capacity (higher numerical ratings) are acceptable.

B17.14.3 All extinguishers must be equipped with a manufacturer installed pressure/charge gauge.

B17.14.4 Except for the initial inspection, one extinguisher must readily be available in the team's paddock area, and the second must accompany the vehicle wherever the vehicle is moved. Both extinguishers must be presented with the vehicle at Technical Inspection.

B17.14.5 As a team option, commercially available on-board fire systems are encouraged as an alternative to the extinguisher that accompanies the vehicle.

B17.14.6 Hand held fire extinguishers are **not** permitted to be mounted on or in the car.

Note: Halon extinguishers and systems are prohibited.

B17.15 Push Bar

B17.15.1 Each car must have a removable device that attaches to the rear of the car that allows two (2) people, standing erect behind the vehicle, to push the car around the event site.

B17.15.2 This device must also be capable of decelerating, i.e. slowing and stopping the forward motion of the vehicle and pulling it rearwards. It must be presented with the car at Technical Inspection.

ARTICLE 18: POSSIBLE FUTURE RULES CHANGES

Notice of Possible Rule Changes for the 2012 Formula SAE Series

This section is intended to provide teams with advance notice of possible changes to the Formula SAE Rules that are being considered by the Formula SAE Rules Committee. Only changes that might have a significant influence on a team's design and manufacturing decisions are listed.

The changes presented in this section are only possibilities and may not be implemented. This section is provided as information and is not intended to be the final text of the rules under consideration.

Invitation to Comment

Students and faculty advisors are invited to comment on any of the proposed rule changes. The Committee welcomes the input of team members and faculty advisors on all aspects of the rules. Comments should include your (1) name, (2) team, (3) contact information and (4) your engineering or philosophical reasons for supporting or opposing a proposed rule change including any supporting data you care to provide.

This is your chance to be part of the FSAE rules making process. We urge you to send us your views. Please email your comments to: daum@sae.org

Please remember that FSAE is an educational competition which is organized to give you a platform for enhancing your engineering design and project management skills. The Rules are intended to present you with a challenging experience which allows you a high level of design freedom, consistent with fair and equitable operation of the competitions of the FSAE Series.

The significant rules changes that are being considered for 2012 are:

B2.3 – Wheelbase – Proposed Reduced Minimum

It had been proposed that the minimum wheel base be reduced from the current 1525 mm (60") to 1400 mm (55").

B3.9.3 & 3.9.4 - 95th Percentile Male Template – Proposed Addition of Legs

It has been suggested that the current structure of the 95th percentile male template "Percy", figure 2, is difficult to position accurately and consistently because of the wide variation in seat design. To correct this problem and to further insure that the vehicle will, in fact, accommodate a 95th percentile male driver it has been proposed to add legs to the template. Although the exact length of such legs has not been finalized a distance of 915 mm (36 in) from leg pivot point at the center of the "hip" circle to the bottom of the "foot" is being considered.

B4.1 Cockpit Opening – Proposed Smaller Template

The Committee is evaluating whether or not the cockpit opening template, Rules figure 8, is larger than necessary to accommodate a 95th percentile male driver. It has been proposed to reduce the size of the template by approximately 25mm (1 in) on each side thus having width at the position of the shoulders of 500 mm rather than the current 550 mm. The length of the template would **not** change.

The vertical template, figure 9, covered by Rule B4.2 "Cockpit Internal Cross Section" will **not** be altered.

B.9.6 Fuel Tank Filler Neck and Sight Tube – Revision – The requirements for the fuel tank filler neck will be changed to simplify the fueling procedure and increase the accuracy of the Fuel Economy refill measurement. This change makes the sight tube optional and standardizes the upper filler neck. The filler neck maximum angle from vertical will be revised to 30 degrees maximum and the geometry of the fill neck will be specified to allow

for attachment of the single-point refueling rig. The draft rule and technical drawing for the fill neck and required clearance zone will be published to the SAE website for comment. A commercially available fill neck and cap will be chosen so it can be purchased. A drawing will also be posted so teams can manufacture it themselves, if desired.

B10.3 Maximum Sound Level – Proposed Reduction

To reduce the environmental impact of the competition vehicles and to support the mobility industries' efforts to develop greener products, the Committee is considering reducing the maximum sound level specified in Rule B10.3 from 110 dBA to 107 dBA. Before the Committee discusses this proposal any further we would like the input of teams and faculty advisors.

All students and faculty advisors are encouraged to comment on Rule B10.3. Please send us your thoughts on lowering the maximum sound level and provide us **with your engineering and/or philosophical reasons** for supporting, or opposing, the proposed reduction

Cost Event Rule C3.7 “Scoring” – Proposed Revised Points Distribution

The Rules Committee is concerned that teams are not putting as much emphasis on balancing design decisions against their cost as would be demanded in a commercial environment. While we want teams to have the freedom to innovate and try new designs, we also want students to make a cost/benefit analysis on their choices. Accordingly, the Committee is considering revising Cost Event scoring to allocate 80 out of the 100 possible points to the final adjusted cost. The score calculated from the adjusted cost would become the “Price Score” from which points would be deducted based on the accuracy, quality and contents of the submitted report and the real case discussion. By allocating the bulk of the event points to the cost of the car, the team with the most expensive vehicle would receive a maximum of 20 points no matter how great their report or real case presentation. On the other hand if they submitted a poor report, or did a weak real case presentation, they could conceivably end up with negative points. [Please keep in mind that under the current rules the Cost Event score can range from -100 to +100 points.] At the other end of the spectrum, the lowest cost car like would start out with 100 points from which penalties would be deducted for an inaccurate report and/or a weak real case presentation. Thus the lowest cost car would finish first only if supported by an accurate report and a good real case presentation. This proposal would significantly increase the points spread in the Cost Event results.

Design Event Rule C5.13 “Scoring” – Proposed Increase in Design Points

Given that Formula SAE is an engineering design competition, it has been proposed that the distribution of maximum points across the 7 events within the competition be revised to increase the maximum score in the Design Event from 150 to 200 points. The suggested point redistribution would reduce the maximum score in Acceleration from 75 points to 50 points and in Endurance from 300 points to 275 points.

D8.20 Fuel Economy and D8.22 Fuel Economy Scoring Formula - Proposed Change of Event

The Rules Committee is considering replacing the present Fuel Economy with Fuel Efficiency. The Fuel Efficiency is based on a metric of the amount of fuel consumed and the lap time on the endurance course, averaged over the length of the event.

Using less fuel for the Endurance event would raise the Fuel Efficiency score. Completing laps quicker than other teams while using the same amount of fuel would also raise the Fuel Efficiency score. Fuel Efficiency is scored relative to the other teams, the team with the best combination of fuel consumed and lowest lap time will win the Fuel Efficiency event, while the team with the worst combination will receive zero points.

2011 Formula SAE Rules
TECHNICAL DRAWINGS

The figures referenced in Part B “Technical Requirements” follow this page.

HELMET CLEARANCE

50 mm (2 inch) Minimum to ALL drivers and 95th percentile template

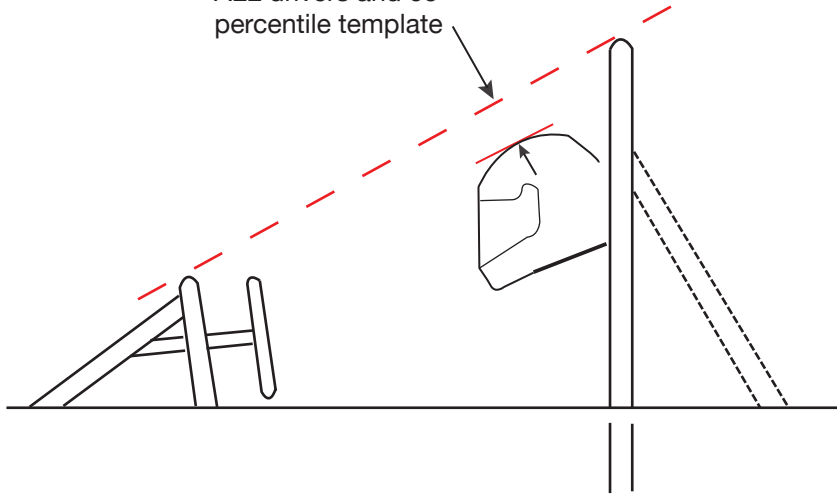

FIGURE 1a

50 mm (2 inch) Minimum to ALL drivers and 95th percentile template

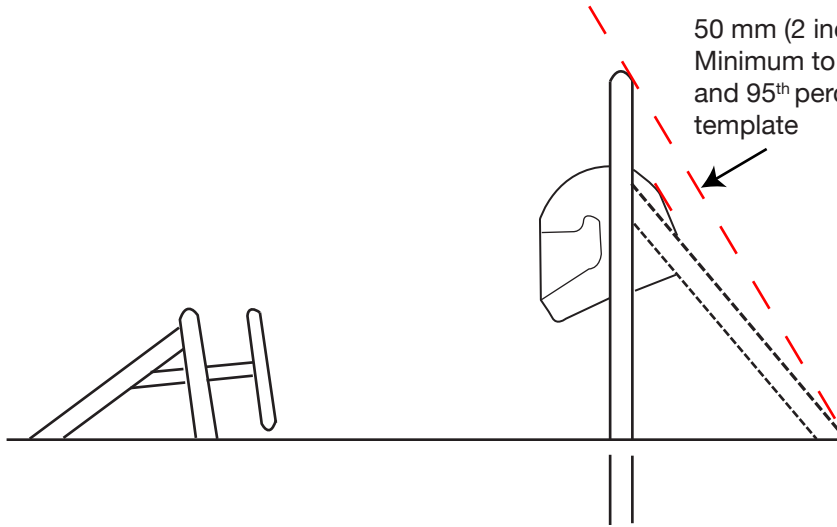

FIGURE 1b

Helmet must not be rearwards of this line when only forward main hoop bracing used

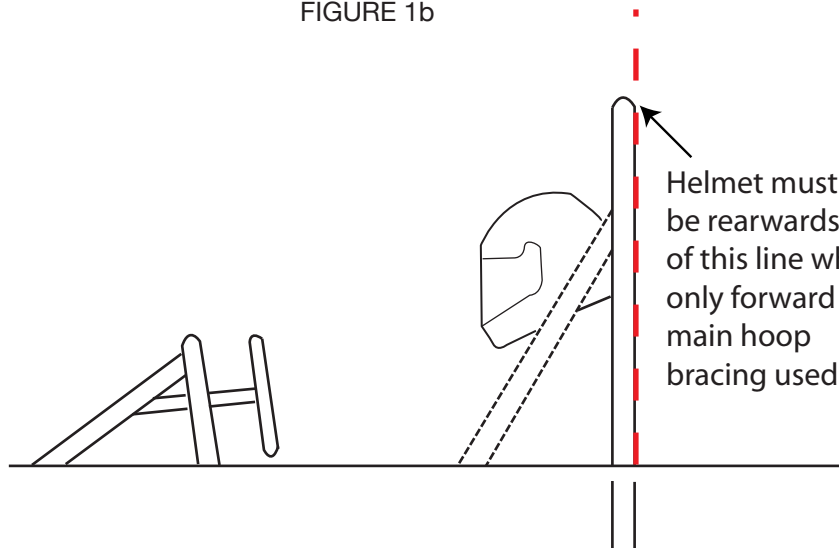
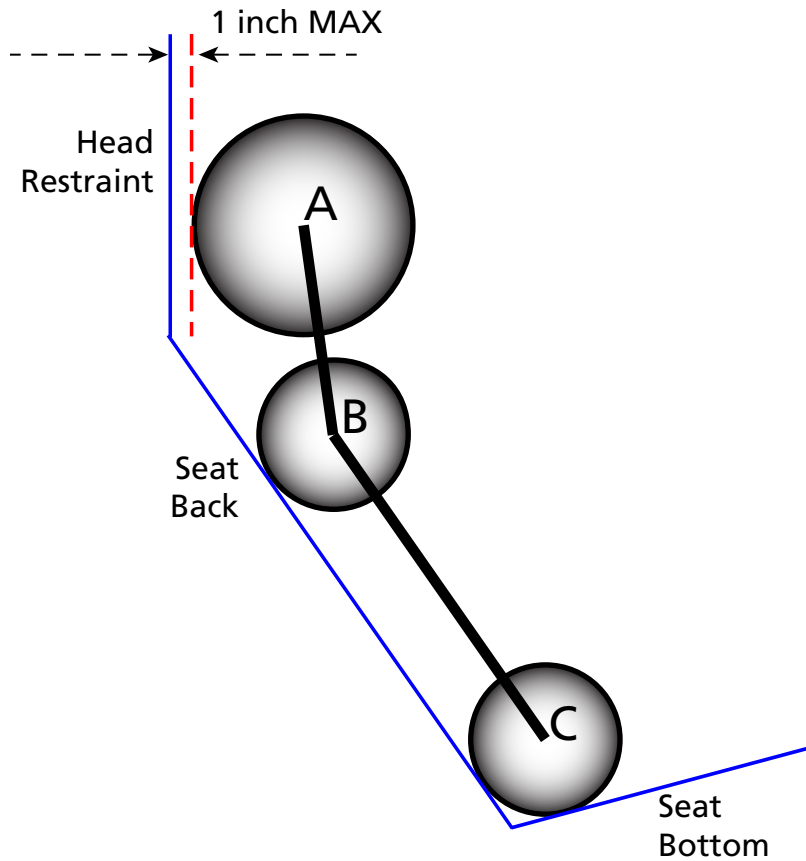

FIGURE 1c

"Percy" – 95th Percentile Male with Helmet



Circle A = Head with helmet – 300 mm diameter

Circle B = Shoulders – 200 mm diameter

Circle C = Hips and buttocks – 200 mm diameter

Line A-B = 280 mm from centerpoint to centerpoint

Line B-C = 490 mm from centerpoint to centerpoint

FIGURE 2

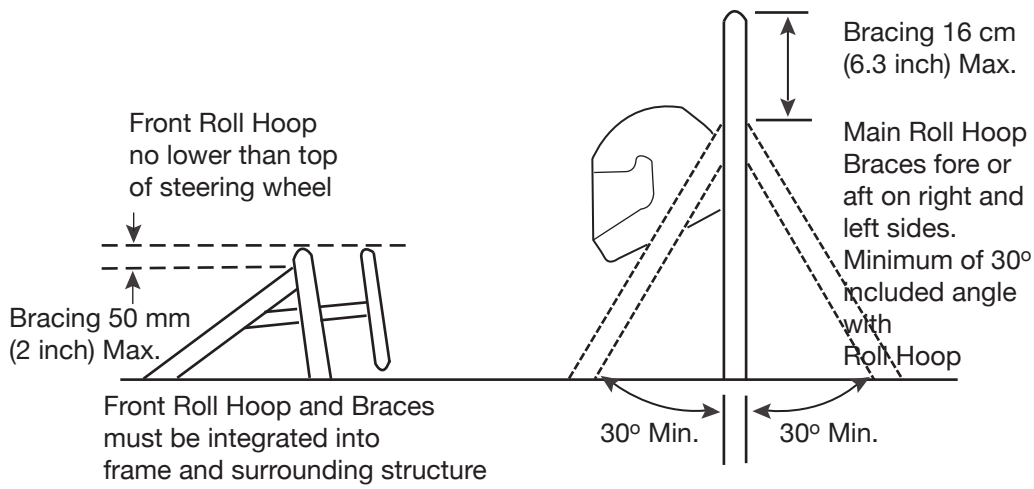

FIGURE 3

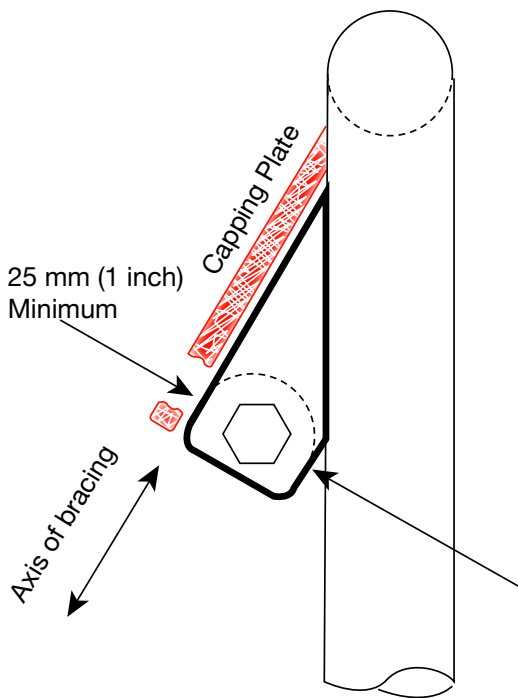

FIGURE 5

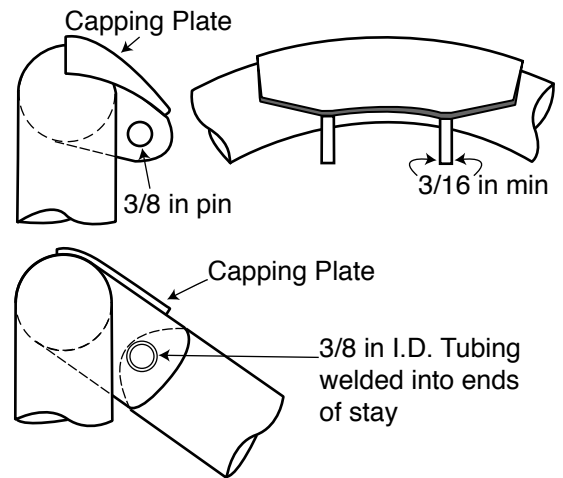

FIGURE 4

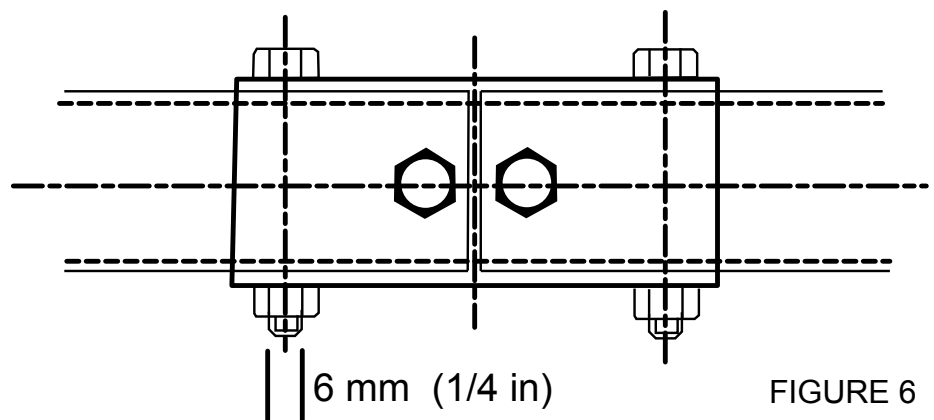

FIGURE 6

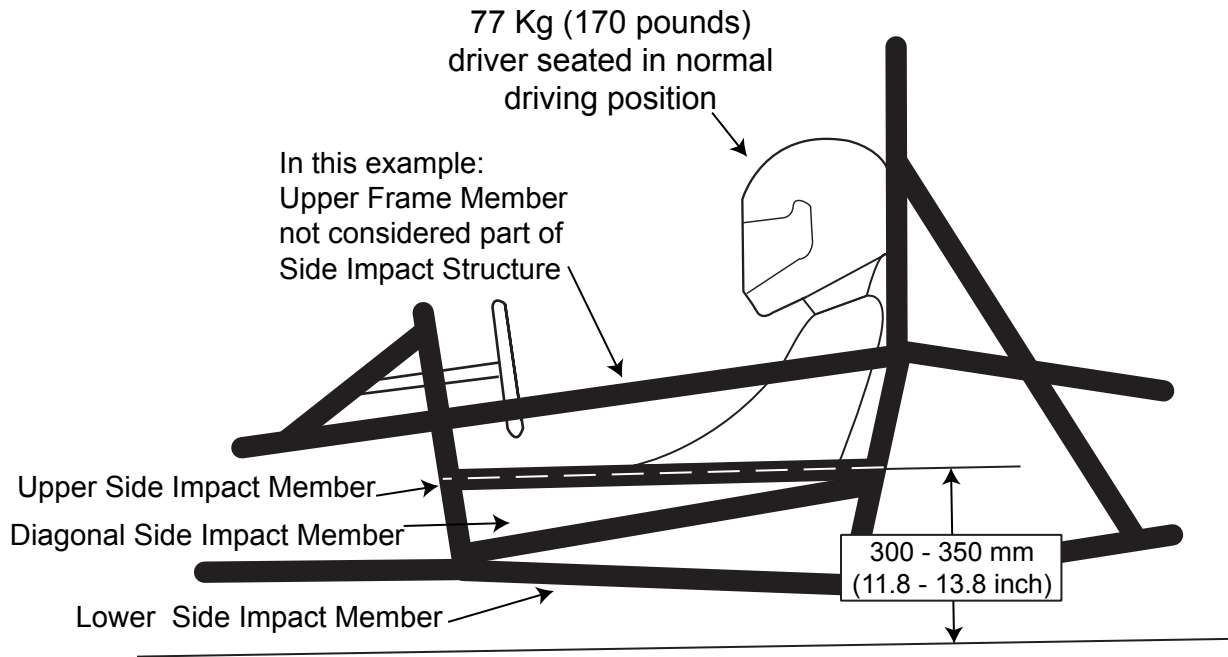

FIGURE 7

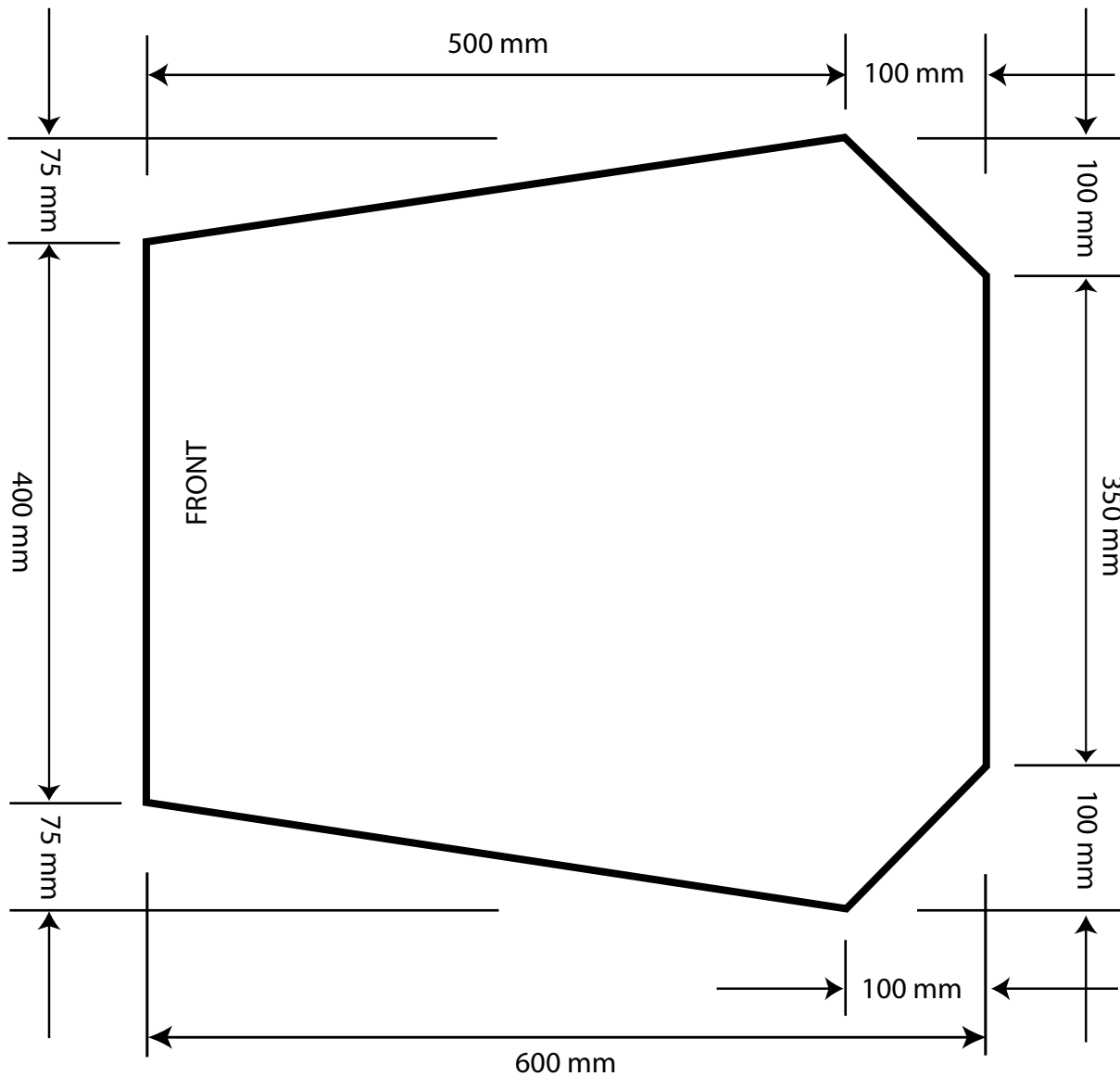

FIGURE 8

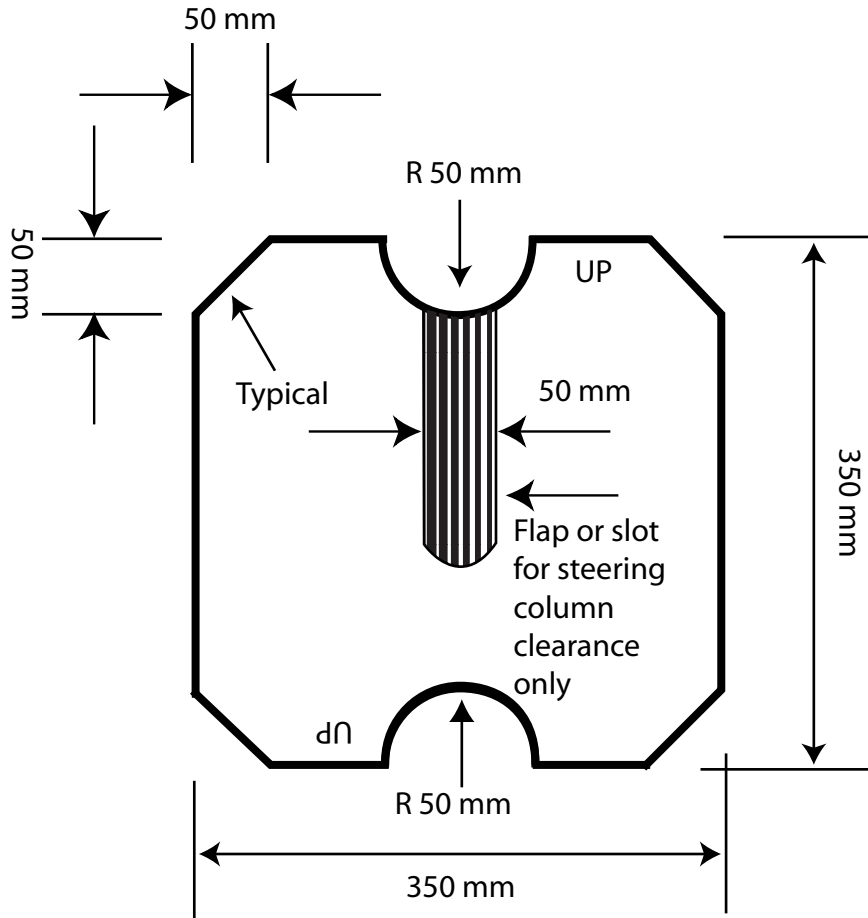

FIGURE 9

FIGURE 10
Lap Belt Angle

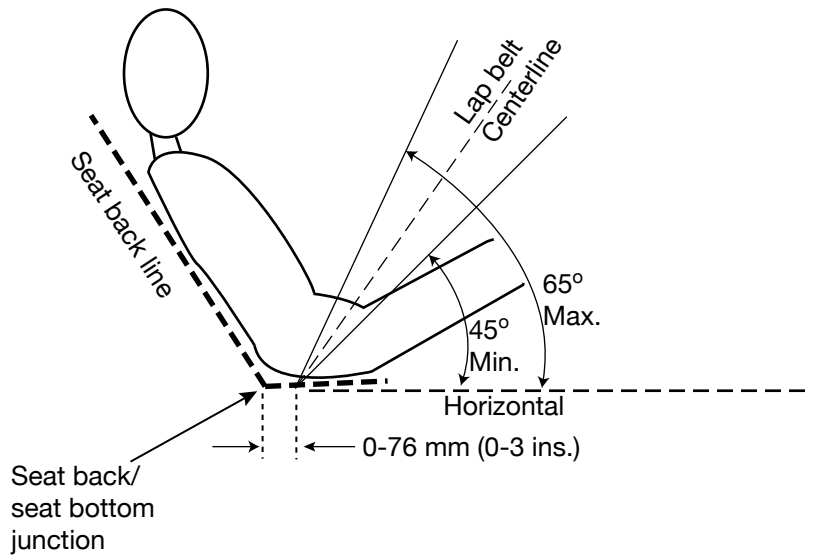

FIGURE 11
Shoulder Harness Mounting Points

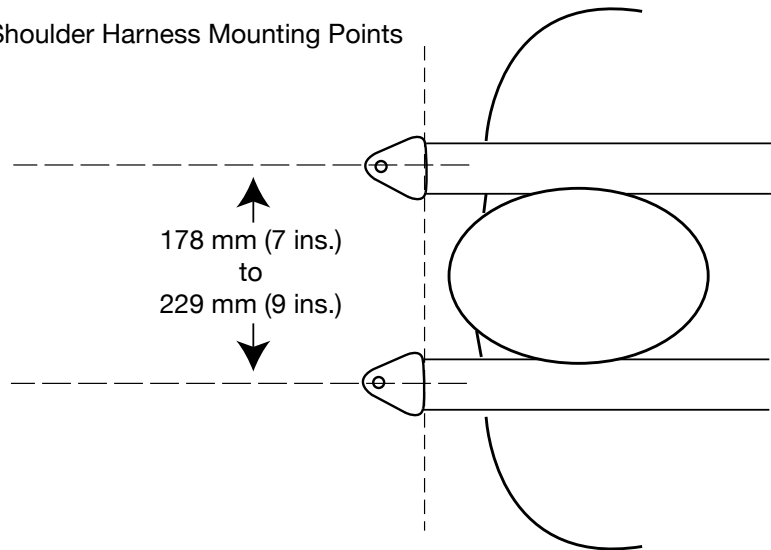
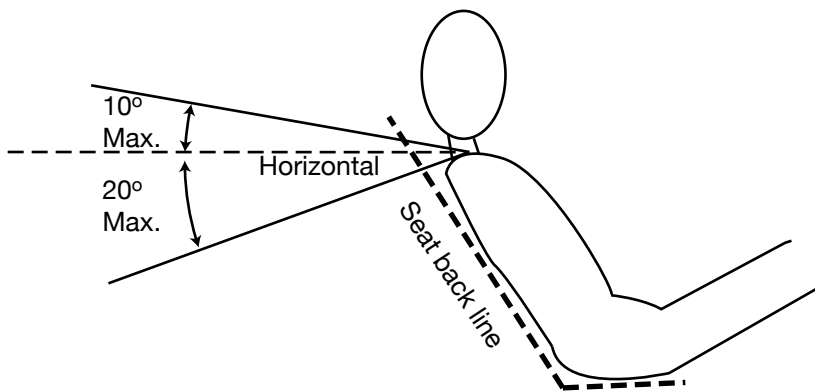
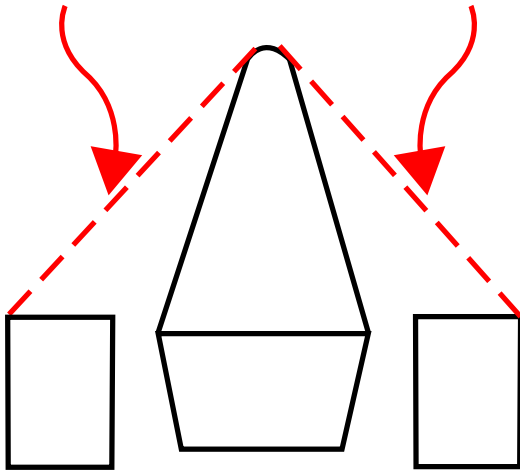

FIGURE 12
Shoulder Harness Angle



REAR VIEW

SURFACE ENVELOPE



SIDE VIEW

SURFACE ENVELOPE

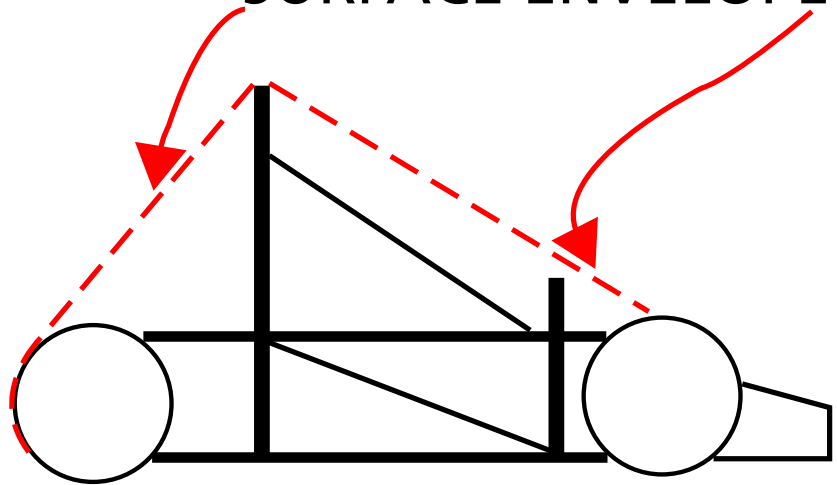

FIGURE 13

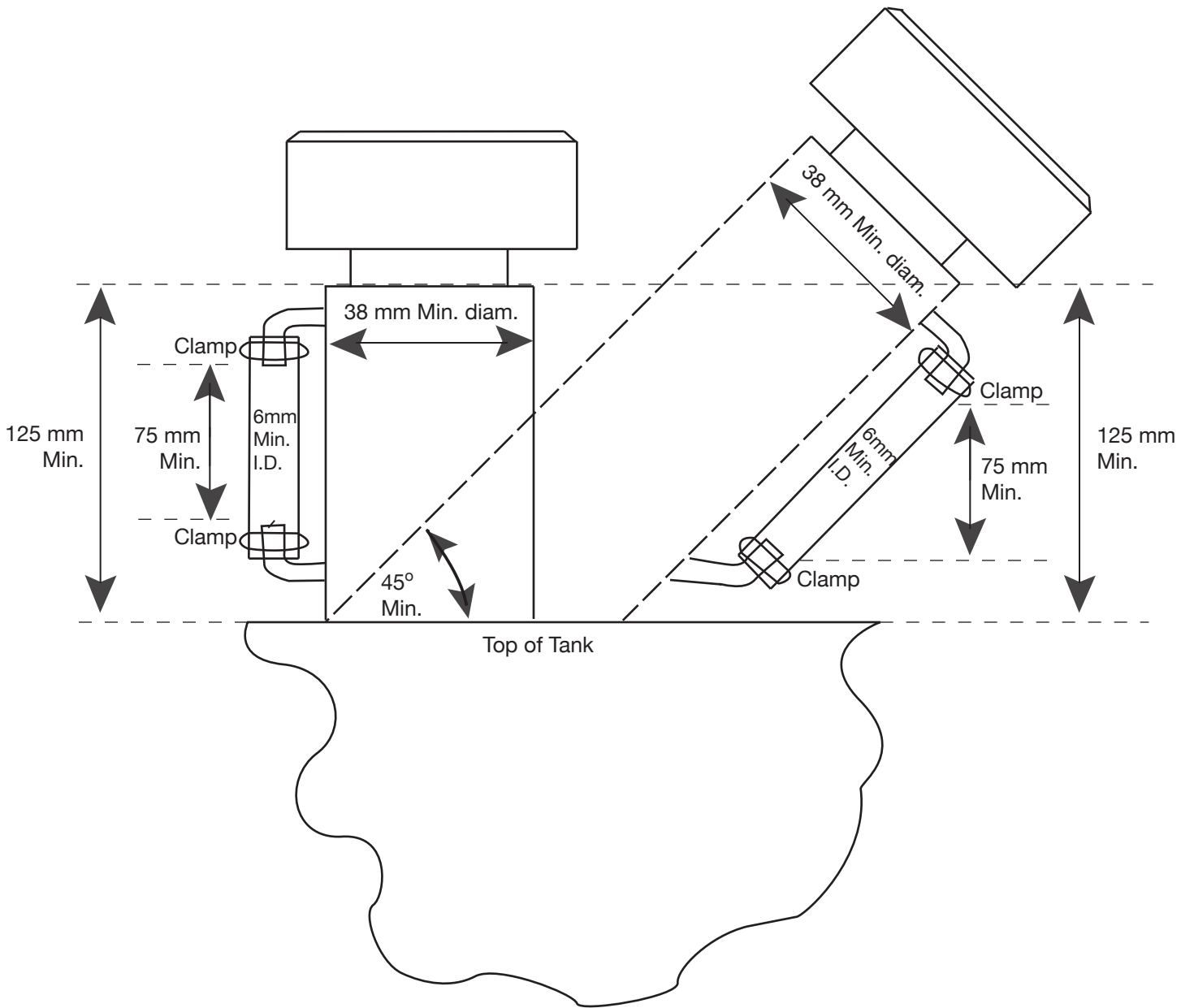

FIGURE 14

APPENDIX AF ALTERNATIVE FRAME RULES

AF1 GENERAL REQUIREMENTS

These alternative structural requirements are intended to provide teams an alternative approach to the existing rules. The goal of these alternative rules is to provide a simpler alternative for monocoque designs and provide expanded design freedom for space frames and monocoques alike. The intent is not to alter allowable structures but to change the requirement process for showing compliance with the rules.

Note: Generally SI units are used in these alternative frame rules with some dual references.

- AF1.1 Unless listed below under section AF7 “Non-Applicable Rules” all requirements of the rest of the rules apply in these alternative requirements.
- AF1.2 The AF Rules are considered a work in progress. As such, the Rules Committee and reviewers of the SRCF (below) may, at any time, amend and clarify these rules to maintain the spirit in which they were written and close any unintended loop holes.
- AF1.2.1 Although the substance AF Rules will not be changed during the 2011 FSAE competition season, supplements and clarifications will be posted on the FSAE website and emailed to teams using these rules. Therefore, teams using these rules must (1) monitor the website and (2) make sure that the email address the Committee has for the team member(s) who are to receive emails concerning the AF Rules are corrected as needed.
- AF1.3 These rules are recommended for existing teams who have experience designing, constructing and competition with vehicles in the past. There is no experience requirement.
- AF1.4 Notice of Intent - Teams planning to build a vehicle to this alternative rule set for entry into a North American competition must notify the Rules Committee of their intent by November 1, 2010. Include a short paragraph detailing your team’s finite element capability and showing you can meet all analytical requirements specified in this Appendix. Your “Notice of Intent” should include the email addresses and phones numbers of the team members who can answer any questions the Committee may have about your proposal.

The notice of intent submission should also include a brief report analyzing the sample structures problem posted to the SAE website. Please include a brief text description of your analysis approach, what software you used, the element types, mesh quality and boundary conditions that were used in this analysis. The results provided will be used to assess the team’s capability to perform this type of structural analysis.

The Rules Committee will remain in contact with teams using the AF rules to help them develop and document their frames and to give the Committee data and feedback that can be used to refine the AF rules.

AF1.5 Notice of Intent – Procedure

- A Address – Teams using the AF Rules for a 2011 competition in North America must submit their “Notice of Intent” to the FSAE Rules committee at: katklauz@aol.com.
- B Due Date – “Notices of Intent” to use the AF Rules for to 2011 vehicle must be submitted to the Rules Committee by 11:59 pm November 1, 2010.

- C Acknowledgement – The Rules Committee will review your “Notice of Intent” and respond with their approval/disapproval within 15 days.

AF2 STRUCTURAL REQUIREMENTS CERTIFICATION FORM (SRCF)

The Structural Requirements Certification Form is similar to the Structural Equivalency Form. Since there is no baseline steel design in this alternative rule set, the team must show they are meeting the functional structural requirements.

- AF2.1 When the Alternate Frame Rules are used the Structural Requirements Certification Form (SRCF) **supersedes** the Structural Equivalency Form (SEF) which **does not** have to be submitted.

AF2.2 SRCF - Submission Process

- A Address – SRCFs must be submitted to the officials at the competition you are entering at the address indicated on the competition website or shown in the Appendix.
- B Due Date and Late Submission Penalty – SRCFs must be submitted no later than the due date specified on the competition website (For US events reference “Action Deadlines”). Teams that submit their SRCF after the relevant due date will be penalized ten (10) points per day up to a maximum of fifty (50) points which will be deducted from the team’s total score.
- C Acknowledgement – North American Competitions – SRCFs submitted for vehicles entered into competitions held in North America will be acknowledged upon receipt.

AF3 DEFINITIONS

The following additional definitions apply throughout the Rules document in addition to the ones listed in B3.2

- Failure - Tensile, compressive, shear load or buckling critical load lower than the specified load. All failure modes have to be considered for every load case.
- Directions – The following coordinate system and labeling convention is used within these rules
 - Longitudinal (X)
 - Transverse (Y)
 - Vertical (Z)

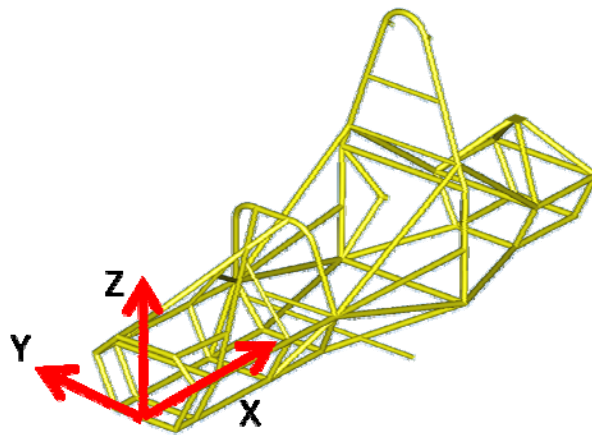

AF4 STRUCTURAL REQUIREMENTS**AF4.1 Main Roll Hoop, Bracing and Bracing Supports**

AF4.1.1 Load Applied: $F_x = 6.0$ kN, $F_y = 5.0$ kN, $F_z = -9.0$ kN

AF 4.1.2 Application point: Top of Main Roll Hoop

AF 4.1.3 Boundary Condition: Fixed displacement (x,y,z) but not rotation of the bottom nodes of both sides of the front and main roll hoops.

AF 4.1.4 Max Allowable Deflection: 25mm

AF 4.1.5 Failure must not occur anywhere in structure

AF 4.2 Front Roll Hoop

AF 4.2.1 Load Applied: $F_x = 6.0$ kN, $F_y = 5.0$ kN, $F_z = -9.0$ kN

AF 4.2.2 Application point: Top of Front Roll Hoop

AF 4.2.3 Boundary Condition: Fixed displacement (x,y,z) but not rotation of the bottom nodes of both sides of the front and main roll hoops.

AF 4.2.4 Max Allowable Deflection: 25mm

AF 4.2.5 Failure must not occur anywhere in structure

AF 4.3 Side Impact

AF 4.3.1 Load Applied: $F_x = 0$ kN, $F_y = 7$ kN, $F_z = 0$ kN. Vector direction of lateral load to be in toward the driver.

AF 4.3.2 Application point: All structural locations between front roll hoop and main roll hoop in the side impact zone defined in B2.1. The analysis may show worst case only but need to support choice of location to justify why it is worst.

AF 4.3.3 Boundary Condition: Fixed displacement (x,y,z) but not rotation of the bottom nodes of both sides of the front and main roll hoops.

AF 4.3.4 Max Allowable Deflection: 25 mm

AF 4.3.5 Failure must not occur anywhere in structure

AF 4.4 Front Bulkhead & Bulkhead Support

AF4.4.1 Load Applied: $F_x = -150$ kN, $F_y = 0$ kN, $F_z = 0$ kN.

AF4.4.2 Application point: use the actual attachment points between the impact attenuator and the front bulkhead

AF 4.4.3 Boundary Condition: Fixed displacement (x,y,z) but not rotation of the bottom nodes of both sides of the main roll hoop and both locations where the main hoop and shoulder harness tube connect. Monocoques should use both sides of the bottom of the main hoop and both sides of the upper attachment point between the main hoop and monocoque.

AF 4.4.4 Max Allowable Deflection: 25mm

AF 4.4.5 Failure must not occur anywhere in structure

AF 4.5 Shoulder Harness Attachment

AF 4.5.1 Load Applied: 13.2 kN at seat belt attachment angle per attachment point.

AF 4.5.2 Application point: Both harness attachment points simultaneously

AF 4.5.3 Boundary Condition: Fixed displacement (x,y,z) but not rotation of the bottom nodes of both sides of the front and main roll hoops.

AF 4.5.4 Max Allowable Deflection: 25mm

AF4.5.5 Failure must not occur anywhere in structure

AF4.6 Lap & Anti-Submarine AF Harness Attachment

AF4.6.1 Load Applied: The loads specified in the monocoque harness attachment rules should be used on each attachment point.

AF4.6.2 Application point: All harness attachment points simultaneously (same load case)

- AF4.6.3 Boundary Condition: Fixed displacement (x,y,z) but not rotation of the bottom nodes of both sides of the front and main roll hoops.
- AF4.6.4 Max Allowable Deflection: 25mm
- AF4.6.5 Failure must not occur anywhere in structure

AF4.4 Front Bulkhead & Bulkhead Support Off Axis

- AF4.4.1 Load Applied: $F_x = -105$ kN, $F_y = 105$ kN, $F_z = 0$ kN.
- AF4.4.2 Application point: Create load application node 150mm forward of the front bulkhead plane at the center of front bulkhead. Load application node may be rigidly connected to the front bulkhead and impact attenuator attachment points.
- AF4.4.3 Boundary Condition: Fixed displacement (x,y,z) but not rotation of the bottom nodes of both sides of the main roll hoop and both locations where the main hoop and shoulder harness tube connect. Monocoques should use both sides of the bottom of the main hoop and both sides of the upper attachment point between the main hoop and monocoque.
- AF4.4.4 Max Allowable Deflection: 25mm
- AF4.4.5 Failure must not occur anywhere in structure

AF5 GENERAL ANALYSIS REQUIREMENTS

The following requirements apply to the submitted structural certification process.

- AF5.1 Good analysis practice must be used and all assumptions and modeling approximations are subject to approval during the SRC process. This includes but is not limited to mechanical properties, mesh size and mesh quality.
- AF5.2 A Nastran analysis deck must be submitted electronically with the SRCF and supporting documentation.
- AF5.3 Tubes with wall thickness less than 1.25 mm (0.049 inches) cannot be included in the analysis
- AF5.4 Holes in tubes may be neglected from the overall frame/monocoque model global results. However for each load case, the force and moments at both sides of the tubes need to be applied to a shell or solid model of the tube with the hole or cutout geometry modeled. The tube around the holes and cutouts may not show failure..
- AF5.5 Offsets between tubes at nodes need a detailed analysis similar to 5.3 where the actual connection is modeled using the end constraints from the overall vehicle model. Shell or solid models must be used.

AF6 INTRUSION PREVENTION

Since the exact configuration of the tubes is not specified this rule is intended to limit the size of object which can intrude into the driver's cell.

- AF6.1 An impactor is defined as a circular disk with diameter of 254 mm (10 inches). The thickness is not relevant, but will generally be around 2mm (0.080 inches) for the inspection process.
- AF6.1 The primary structure between the front bulkhead and main roll hoop must not allow the impactor to enter the primary structure.
- AF6.2 Anywhere on the structure where the impactor is attempted to be passed through the impactor must contact the structure in at least three points. This is not a projection requirement but a full 3-dimensional requirement.

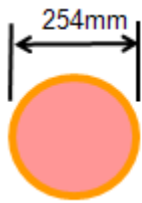

Impactor Check – must not be able to enter frame at any point between front bulkhead and main roll hoop – must contact three points of frame everywhere in side projection

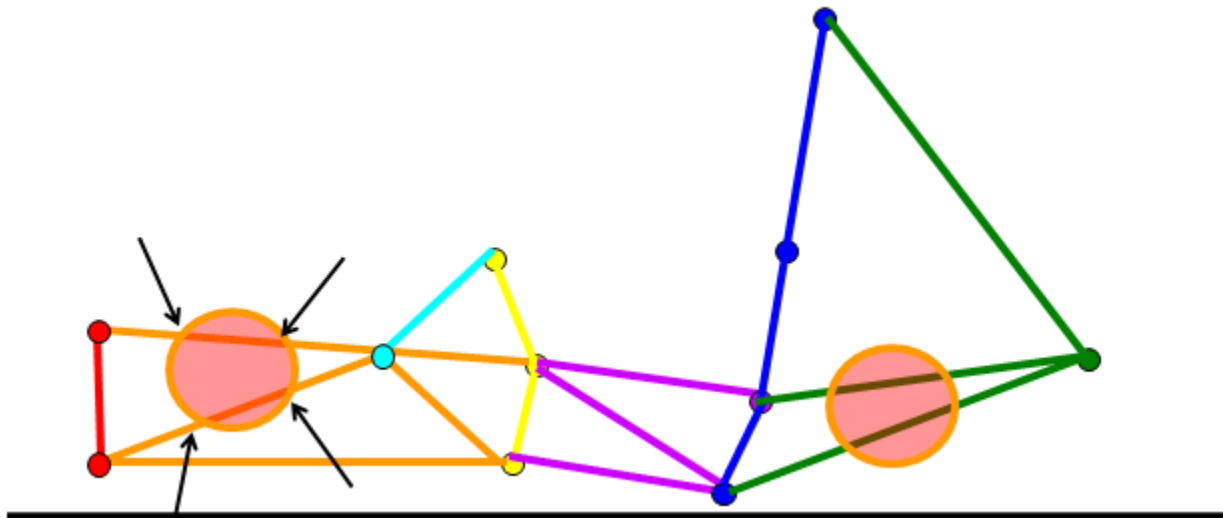

AF6.2 The impactor is a 3-dimensional requirement. It applies to all faces of the structure, including the front, sides, top, floor and rear, excluding only the cockpit opening specified in B4.1.

AF7 NON-APPLICABLE RULES

The following rules are **not** applicable when building a frame to this alternative rule set.

AF7.1 B3.10.4 In the side view of the vehicle, the portion of the Main Roll Hoop that lies above its attachment point to the Major Structure of the Frame must be within ten degrees (10°) of the vertical.

AF7.2 B3.11.6 In side view, no part of the Front Hoop can be inclined at more than twenty degrees (20°) from the vertical.

AF7.3 B3.12.2 The use of aluminum alloys, titanium alloys or composite materials for the Main Hoop braces is prohibited.

AF7.4 B3.12.4 In the side view of the Frame, the Main Hoop and the Main Hoop braces must not lie on the same side of the vertical line through the top of the Main Hoop, i.e. if the Main Hoop leans forward, the braces must be forward of the Main Hoop, and if the Main Hoop leans rearward, the braces must be rearward of the Main Hoop.

AF7.5 B3.12.5 The Main Hoop braces must be attached as near as possible to the top of the Main Hoop but not more than 160 mm (6.3 in) below the top-most surface of the Main Hoop. The included angle formed by the Main Hoop and the Main Hoop braces must be at least thirty degrees (30°). See Figure 3.

- AF7.6 B3.12.6 The attachment of the Main Hoop braces must be capable of transmitting all loads from the Main Hoop into the Major Structure of the Frame without failing. From the lower end of the braces there must be a properly triangulated structure back to the lowest part of the Main Hoop *and the node at which the upper side impact tube meets the Main Hoop*. This structure must meet the minimum requirements for Main Hoop Bracing Supports (see Rule B.3.3) or an SEF approved alternative. Bracing loads must not be fed solely into the engine, transmission or differential, or through suspension components.
- AF7.7 B3.13.4 The Front Hoop braces must be attached as near as possible to the top of the Front Hoop but not more than 50.8 mm (2 in) below the top-most surface of the Front Hoop. See Figure 3.
- AF7.8 B3.13.5 If the Front Hoop leans rearwards by more than ten degrees (10°) from the vertical, it must be supported by additional bracing to the rear. This bracing must be constructed of material per Rule B.3.3.1.
- AF7.9 B3.19.1 The Front Bulkhead must be securely integrated into the Frame.
- AF7.10 B3.19.2 The Front Bulkhead must be supported back to the Front Roll Hoop by a minimum of three (3) Frame Members on each side of the vehicle with one at the top (within 50.8 mm (2 inches) of its top-most surface), one (1) at the bottom, and one (1) as a diagonal brace to provide triangulation.
- AF7.11 B3.19.3 The triangulation must be node-to-node, with triangles being formed by the Front Bulkhead, the diagonal and one of the other two required Front Bulkhead Support Frame Members.
- AF7.12 B3.24.4 With proper gusseting and/or triangulation, it is permissible to fabricate the Side Impact Structural members from more than one piece of tubing.

**APPENDIX B-1
2011 FSAE™ STRUCTURAL EQUIVALENCY FORM – Page 1 of 2**

This form must be completed and submitted by **all teams no later than the date specified in the Action Deadlines on specific event website**. The FSAE Technical Committee will review all submissions which deviate from the FSAE® rules and reply with a decision about the requested deviation. All requests will have a confirmation of receipt sent to the team. Structural Equivalency Forms (SEF) and supporting calculations must be submitted electronically in Adobe Acrobat Format (*.pdf). The submissions must be named as follows: schoolname_sef.pdf using the complete school name. **Please submit to the person indicated in the Action Deadlines for each event.**

***In the event that the FSAE Technical Committee requests additional information or calculations, teams have one week from the date of the request to submit the requested information.**

University Name _____ Car Number(s) & Event(s) _____
 Team Contact _____ E-mail Address _____
 Faculty Advisor _____ E-mail Address _____

Is proof of equivalency for your design required for any of the rules?
 ___Yes. Alternative material was used to that specified in B.3.3.1
 ___No. Chassis did not deviate from baseline requirements

Baseline Material Used	Alternative Material Used	Rule No.	Rule Description	Design Description and/or Material Used
		B3.10	Main Roll Hoop Tubing	
		B3.11	Front Roll Hoop Tubing	
		B3.12	Main Roll Hoop Bracing Tubing	
		B3.13	Front Hoop Bracing – Tube Frames	
		B3.18	Front Bulkhead – Tube Frames	
		B3.19	Front Bulkhead Support – Tube Frames	
		B3.20.6	Impact Attenuator Anti-intrusion Plate	
		B3.24	Side Impact Systems – Tube Frames	
		B3.32	Main Hoop Attachment – Monocoque	
		B3.33	Front Hoop – Monocoque	
		B3.34	Main Hoop Bracing Attach – Monocoque	
		B3.33	Front Hoop Bracing – Monocoque	
		B3.29	Front Bulkhead – Monocoque	
		B3.30	Front Bulkhead Support – Monocoque	
		B3.31	Side Impact System – Monocoque	
		B3.20.3	Impact Attenuator Attach – Monocoque	
		B5.2.4	Safety Harness Attach – Monocoque	
		B5.4.1	Shoulder Harness Bar	

Attachment Checklist (make sure all are included in your report)

- ✓ Receipt, letter of donation or proof for non-steel materials (composite, honeycomb, resin, etc).
- ✓ Properties for all non-steel materials
- ✓ Monocoque Laminate Testing data and pictures
- ✓ Holes drilled in any regulated tubing require a deviation, include area and moment of inertia

ATTACH PROOF OF EQUIVALENCY

Please see "[Structural Equivalency Guide](#)" on SAE website for more information about the proof of equivalency.

TECHNICAL COMMITTEE DECISION/COMMENTS

Approved by _____ Date _____

NOTE: THIS FORM AND THE APPROVED COPY OF THE SUBMISSION MUST BE PRESENTED AT TECHNICAL INSPECTION AT EVERY FORMULA SAE EVENT ENTERED

APPENDIX B-1
2011 FSAE™ STRUCTURAL EQUIVALENCY FORM Page 2 of 2

University Name _____ Car Number(s) & Event(s) _____

Please attach pictures of the frame and/or monocoque below for review during the SEF process. Please label all tubes to show outer diameter and wall thickness. Three view drawings and isometric views of the structure (CAD, FEA models, etc) are acceptable. Note: The final decision about all designs will be made at technical inspection. Approval of an SEF does not guarantee passing Technical Inspection.

**APPENDIX B-2
2011 FSAE™ IMPACT ATTENUATOR DATA REPORT – Page 1 of 3**

This form must be completed and submitted by **all teams no later than the date specified in the Action Deadlines on specific event website**. The FSAE Technical Committee will review all submissions which deviate from the FSAE® rules and reply with a decision about the requested deviation. All requests will have a confirmation of receipt sent to the team. Impact Attenuator Data (IAD) and supporting calculations must be submitted electronically in Adobe Acrobat Format (*.pdf). The submissions must be named as follows: schoolname_IAD.pdf using the complete school name. **Please submit to the person indicated in the Action Deadlines for each event.**

***In the event that the FSAE Technical Committee requests additional information or calculations, teams have one week from the date of the request to submit the requested information or ask for a deadline extension.**

University Name _____ Car Number(s) & Event(s) _____
 Team Contact _____ E-mail Address _____
 Faculty Advisor _____ E-mail Address _____

Is proof of equivalency for your design required for any of the rules? <input type="checkbox"/> Yes. Alternative design used <input type="checkbox"/> No. Impact Attenuator did not deviate from baseline requirements
--

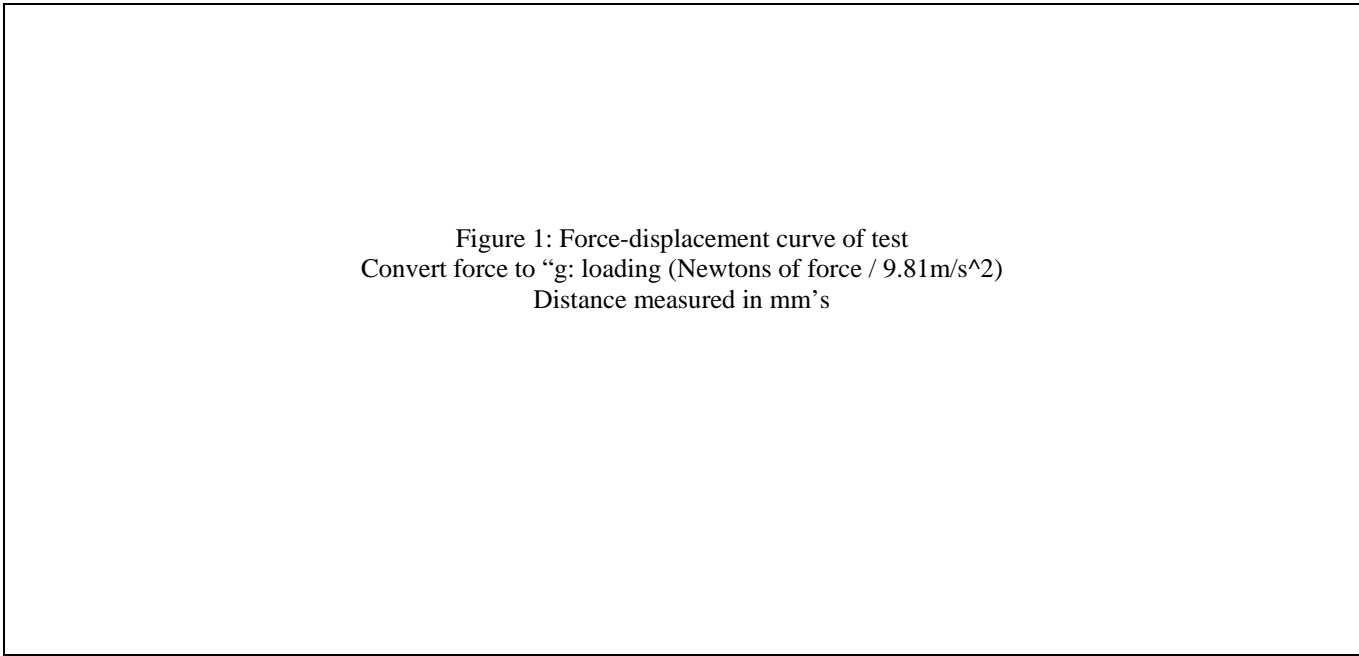

Figure 1: Force-displacement curve of test
 Convert force to “g: loading (Newtons of force / 9.81m/s^2)
 Distance measured in mm’s

Figure 1: Force-Displacement Curve

**ATTACH PROOF OF EQUIVALENCY
 TECHNICAL COMMITTEE DECISION/COMMENTS**

Approved by _____ Date _____

**NOTE: THIS FORM AND THE APPROVED COPY OF THE SUBMISSION MUST BE PRESENTED
 AT TECHNICAL INSPECTION AT EVERY FORMULA SAE EVENT ENTERED**

**APPENDIX B-2
2011 FSAE™ IMPACT ATTENUATOR DATA REPORT – Page 2 of 3**

University Name _____ Car Number(s) & Event(s) _____

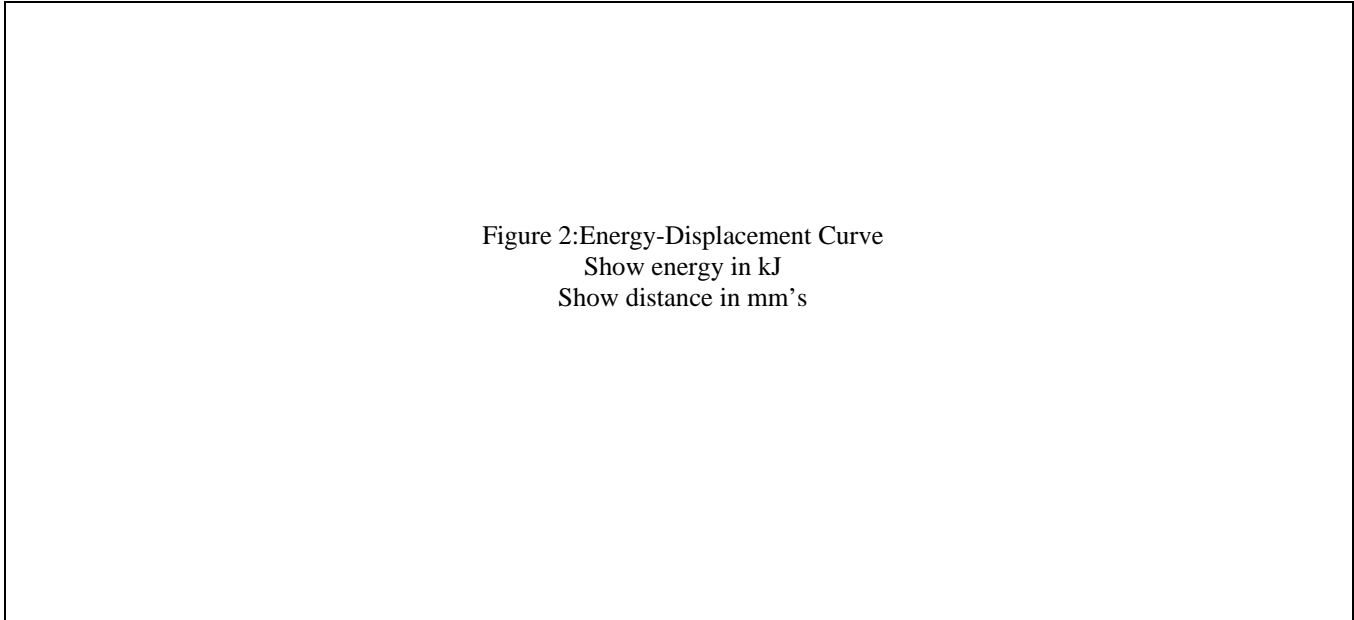
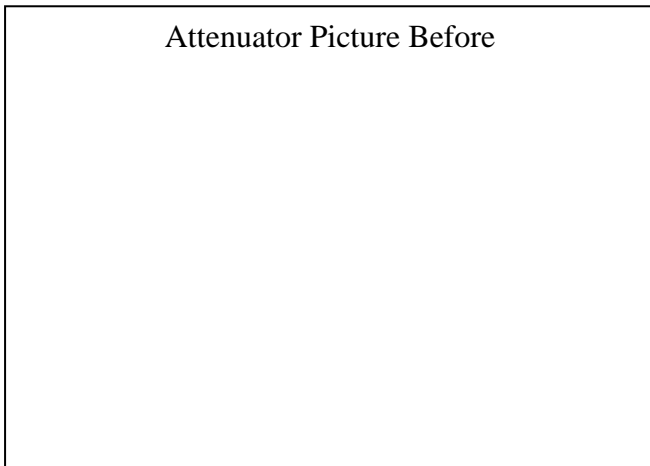
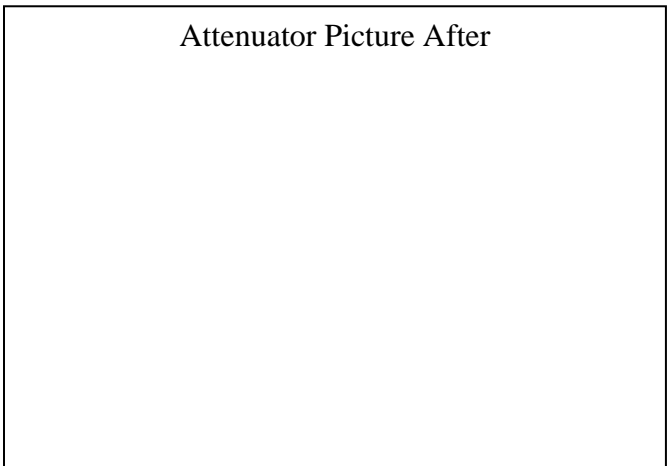

Figure 2: Energy-Displacement Curve
Show energy in kJ
Show distance in mm's

Figure 2: Energy-Displacement Curve



Attenuator Picture Before



Attenuator Picture After

Figure 3: Attenuator As Constructed

Figure 4: Attenuator After Impact

Max G Load: _____ g's Value <= 40g's: _____ (Yes or No)
 Average G Load: _____ g's Value <= 20g's _____ (Yes or No)
 Energy Absorbed: _____ kJ Value >= 7350 kJ: _____ (Yes or No)
 Vehicle includes front wing in front of front bulkhead _____ (Yes or No)
 Wing structure included in test? _____ (Yes or No) If wing equipped it must be included in the test
 Test type: _____ (e.g. barrier test, drop test, quasi-static crush)
 Test site: _____ (must be from approved test site list on website for dynamic tests)

**APPENDIX B-2
2011 FSAE™ IMPACT ATTENUATOR DATA REPORT – Page 3 of 3**

University Name _____ Car Number(s) & Event(s) _____

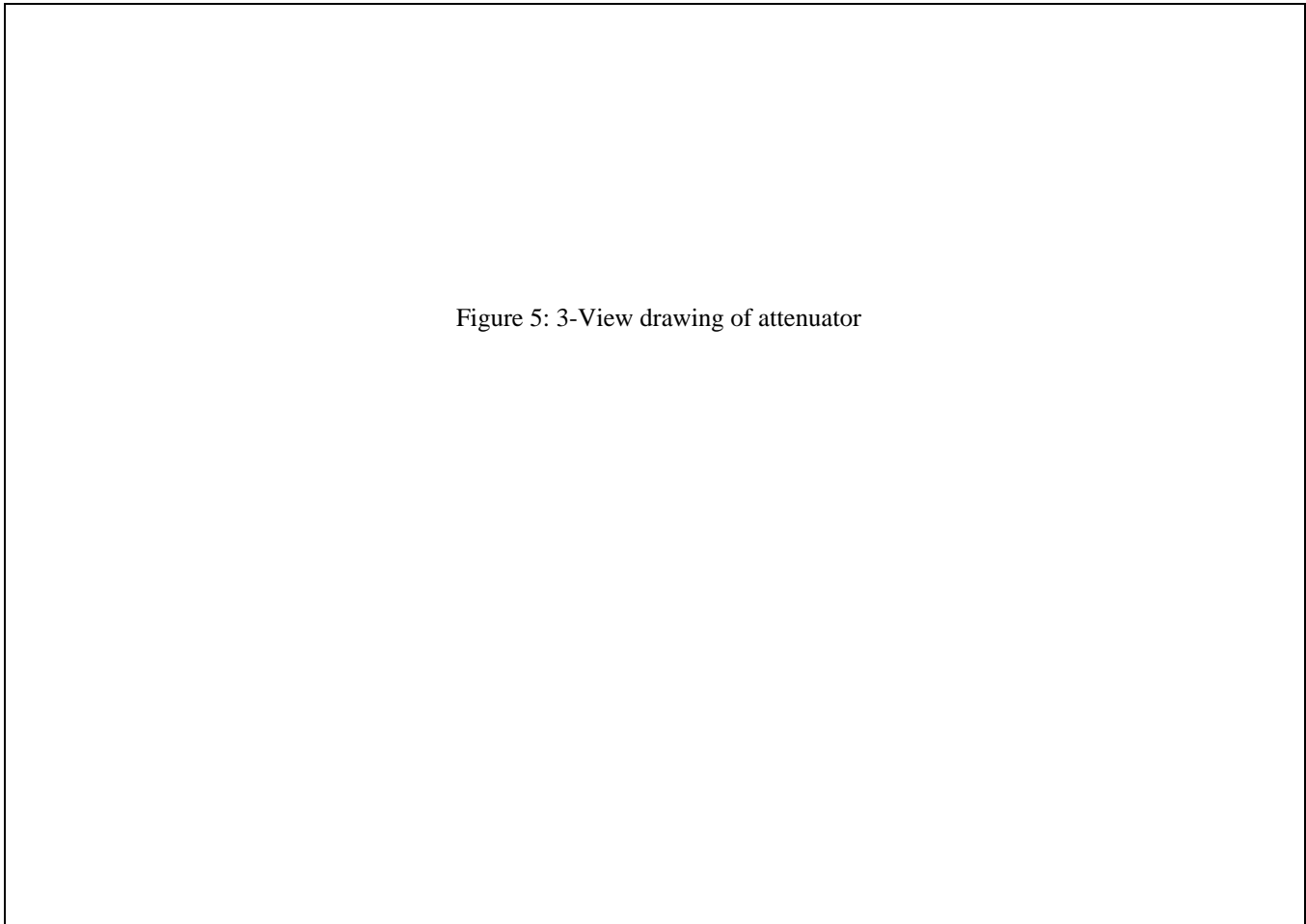

Figure 5: 3-View drawing of attenuator

Figure 5: Design Drawings

Length (fore/aft direction): _____ ($\geq 200\text{mm}$)
 Width (lateral direction): _____ ($\geq 200\text{mm}$)
 Height (vertical direction): _____ ($\geq 100\text{mm}$)
 Attenuator is at least 200mm wide by 100mm high for at least 200mm: _____ (Yes or No)

Attach additional information below this point and/or on additional sheets

2011 FORMULA SAE PART C – STATIC EVENT REGULATIONS

ARTICLE 1: STATIC EVENTS AND MAXIMUM SCORES

The maximum possible scores in the static events are:

Technical Inspection	No Points
Cost and Manufacturing	100 Points
Presentation	75 Points
<u>Design</u>	<u>150 Points</u>
Total	325 Points

ARTICLE 2: TECHNICAL INSPECTION

C2.1 Objective of Technical Inspection

The objective of technical inspection is to determine if the vehicle meets the FSAE Rules requirements and restrictions and if, considered as a whole, it satisfies the intent of the Rules.

C2.1.1 For purposes of interpretation and inspection the violation of the intent of a rule is considered a violation of the rule itself. (See Rule A.3.6)

C2.1.2 Technical inspection is a non-scored activity.

C2.2 Inspection & Testing Requirement

Each vehicle must pass all parts of technical inspection and testing, and bear the inspection stickers, before it is permitted to participate in any dynamic event or to run on the practice track.

C2.2.1 All items on the Inspection Form must be clearly visible to the technical inspectors.

C2.2.2 Visible access can be provided by removing body panels or by providing removable access panels.

C2.3 Team Responsibility

Teams are responsible for confirming that their vehicle, and the required equipment, satisfies the requirements and restrictions of the FSAE Rules before presenting it for Technical Inspection.

C2.3.1 Presenting a vehicle for Technical Inspection constitutes a declaration by the team that they have determined by self inspection that the vehicle complies with the Rules.

C2.4 Items to be Inspected

The following items **must** be brought to Technical Inspection:

- Vehicle
- Technical Inspection Form
- Dry and wet tires
- Driver's equipment - for all drivers including arm restraints, helmets, suits, gloves, eye protection, balaclavas, socks and shoes.
- Fire extinguishers
- Push bar

- *Structural Equivalency Form (SEF) copies or Structural Requirements Certification Form (SRCF) copies, as appropriate for your car.*
- *Impact Attenuator Report copies*
- *Copies of any rules questions you submitted with the answer you received.*
- All drivers must be present at inspection.

C2.5 Technical Inspection Procedure

Technical inspection will examine all items included on the Inspection Form found on the SAE website plus any other items the inspectors may wish to examine to ensure conformance with the Rules. The exact procedures and instruments employed for inspection and testing are entirely at the discretion of the Chief Technical Inspector.

- C2.5.1 Decisions of the inspectors and the Chief Technical Inspector concerning vehicle compliance are final and are not permitted to be appealed.

C2.6 Inspection Condition

Vehicles must be presented for technical inspection in finished condition, i.e. fully assembled, complete and ready-to-run. Technical inspectors will not inspect any vehicle presented for inspection in an unfinished state.

Note: Cars may be presented for technical inspection even if final tuning and set-up has not been finished.

C2.7 Inspection Process

Vehicle inspection will consist of three separate parts as follows:

C2.7.1 Part 1 – Scrutineering

Each vehicle will be inspected to determine if it complies with the requirements of the rules. This inspection will include examination of the driver's equipment (Article B.17) and a test of the driver egress time (Rule B.4.8).

Part 1 must be passed before a vehicle may apply for Part 2 and Part 3 inspection.

C2.7.2 Part 2 – Tilt Table Tests

Each vehicle will be tested to insure it satisfies both the forty-five degree (45°) fuel and fluid tilt requirement (Rule B .9.9) and the sixty degree (60°) tilt table requirement (Rule B.6.7).

Parts 1 and 2 must both be passed before a vehicle may apply for Part 3 inspection.

C2.7.3 Part 3 – Noise, Master Switch, and Brake Tests

Noise will be tested by the specified method (Rule B.10.2). If the vehicle passes the noise test then its master switches will be tested (see Rule B.11.1). If the vehicle passes both the noise and master switch tests then its brakes will be tested by the specified method (see Rule B.7.2).

C2.8 Correction and Re-inspection

- C2.8.1 If any part of a vehicle does not comply with the Rules, or is otherwise deemed to be a concern, then the team must correct the problem and have the car re-inspected.

- C2.8.2 The judges and inspectors have the right to re-inspect any vehicle at any time during the competition and require correction of non-compliance.

C2.9 Inspection Stickers

Inspection stickers issued following the completion of any part of Technical Inspection will be placed on the upper nose of the vehicle as specified in Rule B.16.4 “Technical Inspection Sticker Space”.

C2.9.1 Inspection stickers are issued contingent on the vehicle remaining in the required condition throughout the competition.

C2.9.2 Inspection stickers may be removed from vehicles that are not in compliance with the Rules or are required to be re-inspected.

C2.10 “As-Approved Condition”

Once a vehicle has passed inspection, except as specifically allowed under Rule B.1.2 “Modification and Repairs”, it must remain in the “As-approved” condition throughout the competition and must not be modified.

C2.11 Inspection Validity

Technical approval is valid only for the duration of the specific Formula SAE competition during which the inspection is conducted.

ARTICLE 3: COST AND MANUFACTURING EVENT

Important Notice: Additional information about the Cost and Manufacturing Event including Cost Tables, Software downloads, authentication number instructions and other information can be obtained from the “Dedicated Cost Website” linked off the Formula SAE Rules and Important Documents page on SAE’s Event Website.

C3.1 Event Objective

The objectives of the Cost and Manufacturing Event are:

- a. To teach the participants that cost and budget are significant factors that must be considered in any engineering exercise.
- b. For teams to make trade off decisions between content and cost based on the performance advantage of each part and assembly.
- c. To gain experience with creating and maintaining a Bill of Material (BOM).
- d. For the participants to learn and understand the principles of Design for Manufacture and Assembly, lean manufacturing and Minimum Constraint Design.

C3.2 Rules Objective

The objectives of the Cost and Manufacturing Event rules are:

- a. To provide a logical, simple and time efficient rule set enabling students to achieve the event’s objectives.
- b. To improve fairness by providing consistent pricing guidelines independent of team geographical location by using standardized Cost Tables.
- c. To require the minimal burden of supporting documentation such as receipts or catalog pages. However, in order to convey design information to cost judges engineering documentation (drawings, process descriptions, etc) are required.

C3.3 Event Requirements

This event is comprised of three (3) parts

- C3.3.1 Part 1 “Cost Report”
The preparation and submission of a report (the “Cost Report”), which is to be sent to the Cost Judges prior to the competition. See C.3.8.
- C3.3.2 Part 2 “Discussion”
A discussion at the Competition with the Cost Judges around the team’s vehicle. See Section C3.21. This evaluates not only the cost of the car, but also the team’s ability to prepare accurate engineering and manufacturing cost estimates.
- C3.3.3 Part 3 “Real Case”
A “real case” scenario where students will have to respond to a challenge related to cost or manufacturing of the student vehicle.
- C3.4 Formula SAE Michigan & Formula SAE California Reports**
Teams that are entering more than one North American competition may submit one (1) Cost Report covering all the competitions entered providing that (a) the report properly identifies the competition names and car numbers and (b) any addenda necessary to cover changes or modifications made to the vehicle between events is properly completed and submitted.
- C3.5 Definitions**
The following definitions will apply throughout the Cost Event rules:
- C3.5.1 Adjusted Cost – The final cost for the vehicle including penalties
- C3.5.2 Amended Cost – The cost of the vehicle after modification by the competition addendum
- C3.5.3 Bill of Material – A hierarchical list of all parts of the vehicle. A BOM lists every item that is on the vehicle but also shows the relationships between these items, for example showing the parts that make up an assembly. A Costed Bill of Material (CBOM) is a standard BOM that includes cost information including cost of purchased parts, raw materials and processes that go into manufacturing the vehicle.
- C3.5.4 Category - Each table has numerous entries which describe a classification of entry. For example there are several types of hose clamps, and all have various costs. The category of hose clamp may be worm drive, constant tension, etc.
- C3.5.5 Cost – The cost for each item from the materials table is simply the quantity multiplied by the unit cost.
- C3.5.6 Cost Report – All materials, including electronic and hard copy, submitted for judging
- C3.5.7 Cost Score – Refers to the total number of points out of 100 earned in the Cost Event
- C3.5.8 Cost Tables – All tables that list costs for objects and processes
- C3.5.9 Design for Manufacture and Assembly (DFMA) – The process where parts are designed for ease of manufacture and assembly, resulting in lower cost.
- C3.5.10 Fasteners Table – A Cost Table that consists of not only traditional fasteners such as bolts, nuts and rivets but also adhesives, hose clamps and retaining rings.
- C3.5.11 Fixed Cost – Costs associated with production that are independent of volume produced. Fixed cost items, such as tooling, are converted to variable costs when included in the Cost Report.

- C3.5.12 Initial Cost – The cost of the vehicle submitted for initial judging in the Cost Report.
- C3.5.13 Lean Manufacture – A methodology for producing goods that emphasizes the elimination of waste and improvement in process flow with the goal of optimizing the cost and quality of goods.
- C3.5.14 Materials Table – Lists the costs for raw materials used to manufacture parts built by the teams and also of finished parts purchased by the teams.
- C3.5.15 Minimum Constraint Design (MCD) – A design methodology emphasizing elimination of redundant constraints in the attachment of parts. Each part requires constraint in six degrees of freedom and additional constraints can make assembly difficult, force tight tolerances and increase the cost of manufactured goods.
- C3.5.16 Parameters – Used to create an equation describing the cost of an object as a function of some characteristic of that object. For example the cost of steel is proportional to the mass (or volume) of steel. In this case steel has been parameterized by mass. Rubber hose could be parameterized by diameter. The equations can be linear or non-linear and both 1st and 2nd order equations are used as necessary to build the Cost Tables.
- C3.5.17 Process Multipliers - Modify the standard costs of different operations to account for material and geometric differences in the part.
- C3.5.18 Purchased Parts – Also called bought parts; these items are listed in the Cost Tables in a near as-installed condition. For example wheels, engines and turbochargers are purchased parts. In some cases purchased parts may still require additional processing before they can be assembled to the car. Wheels, for example, do not include the machined features for mounting to the hub. Purchased parts do not include fasteners unless specifically noted in the Cost Tables.
- C3.5.19 Quantity – The amount of the item
- C3.5.20 Raw Materials – Materials used for manufacturing parts, such as aluminum, steel and rubber hose.
- C3.5.21 Tools – Tools refer to hand or power tools used to assemble the vehicle. The costs of these tools **are not included** in the Cost Report. The effect of the tools used for assembly are captured in the process tables for labor as different costs are given based on the tools used for assembly.
- C3.5.22 Tooling - Is the production tooling associated with processes that are specific to the part geometry. The costs of tooling **must be included** in the Cost Report. For example the dies to stamp out a chassis bracket are tooling. The press used to stamp the bracket is not, and is considered production equipment which is not part of the Cost Event.
- C3.5.23 Unit – Is the measurement system used to define the quantity of a parameter. For example millimeters and kilograms are units. The hose clamp diameter unit is mm. When calculating the cost of the clamp the unit of measurement used by the team must match the Unit specified in the tables. For example a US team mistakenly calculates the hose clamp cost by using the expression with a diameter of 1, because their radiator hose is 1 inch in diameter. They should have used 25.4mm for the diameter and their cost is wrong because of it. For the penalties associated with this type of error see C.3.18

C3.5.24 Unit Cost – Is the cost for something assuming a numerical value of one (1) of the unit used to measure the item. The cost is the quantity of an item multiplied by the unit cost.

C3.5.25 Variable Cost – Is a cost associated with production that is proportional to the vehicle volume produced. All costs submitted with the Cost Report will be variable costs.

C3.6 General Requirements

C3.6.1 The Cost Report must:

- a. Use the standardized Cost Tables. The tables are designed to reflect a hypothetical car built for production at the annual volume of 1000 units per year.
- b. List and cost every part on the prototype vehicle. This includes any equipment fitted on the vehicle at any time during the competition. The only exceptions are that, per C.3.22 “Cost Report Exempt Items” of the Rules, the cost of any finish, on-board fire suppression system, rain tires, video or radio system, does not need to be included in the Cost Report.
- c. Be based on the estimated costs of materials, fabrication, purchased parts, and assembly of the car. The costs shall be calculated as defined in these rules.
- d. Be based on the actual manufacturing technique used on the prototype, e.g. cast parts on the prototype must be cost as cast, and fabricated parts as fabricated, etc.
- e. Include tooling (e.g. welding jigs, molds, patterns and dies) for processes requiring it.
- f. Exclude R & D and capital expenditures (e.g. plant, machinery, hand tools and power tools).

Note: There is no maximum cost. Receipts are not required for any items.

C3.6.2 The Cost Tables have been designed to:

- a. Be verifiable at the event. Differentiating between different types of materials (for example different alloys of steel) is not possible so no differentiation is made in the table cost.
- b. Minimize influence on safety equipment content. For example driver harnesses are cost independent of the style chosen.
- c. Higher costs of some goods must reflect actually higher value of those goods. However, the costs must still allow for team innovation and vehicle content, with some reduction in cost score.

C3.7 Scoring

The points for the Cost and Manufacturing Event will be broken down as follows:

$\frac{40x[(P_{max})/(P_{your})-1]}{[(P_{max})/P_{min})-1]}$	40 Points	Lowest cost - each of the participating schools will be ranked by total adjusted cost from the BOM and given 0-40 points based on the formula on the left.
	40 Points	Accuracy, Clarity & Event Day/Visual Inspection - The cars will be reviewed for part content, manufacturing feasibility and accuracy of the cost information. Supporting documentation will be assessed based on its quality, accuracy and thoroughness. The range for the score is 0-40 points.
	20 Points	Event Day/Manufacturing Processes - The teams must be prepared to discuss in detail the “real case” scenario distributed prior to the competition. The materials will include more specifics about the goal and scoring of the scenario. The range for the score is 0-20 points.
Total	100 Points	

Where:

P_{your} is the adjusted cost of your car (with penalties) in dollars.

P_{min} is the adjusted cost of the lowest cost car in dollars.

P_{max} is the cost of the highest cost car in dollars.

C3.8 Cost Report

C3.8.1 The Cost Report consists of a full vehicle BOM with cost data derived from the Cost Tables and supporting documentation. The Cost Report must be submitted in two (2) forms:

- a. Electronic Version – The electronic version must be identified as follows:
 Carnumber_schoolname_competitioncode_CR.xls using the assigned car number, the complete school name and the competition code.
 Example: 087_University of FSAE_FSAEM_CR.xls

Competition Codes are listed in Rule A.2.6

Note: Teams entered into a competition using the Cost Application (See B3.24) need not submit a separate electronic file as usage of the software and synchronization of the local data with the FSAE server before the deadline meets the full requirement for electronic submission.

- b. Hard Copy – The hard copy Cost Report must be in a ring binder with 8.5” x 11” or A4 pages.

Note: Some competitions may waive the hard copy requirement. If so, the waiver will be published on the SAE website.

C3.8.2 Cost Report Identification

The cover of the Cost Report must include the following:

(a) university name, (b) competition name, and (c) vehicle number.

Note: Teams that are submitting a single Cost Report covering more than one North American competition must identify their report as follows:

University Name (full name)

Formula SAE Michigan, Car # XXX and Formula SAE California, Car #YYY

C3.8.3 The Cost Report must consist of the following:

- A Cover sheet
- A Table of Contents
- A Cost Summary page listing each section’s cost, and the total vehicle cost
- Eight commodity report sections with the parts placed in the sections as specified in Appendix C-3.
- Tabs for each section

Note: Teams entered into a competition using the Cost Application (See C3.24) should still include the items above but the cost summary pages can be printed directly from the application.

C3.9 Bill of Materials (BOM)

The BOM is a parts list for every vehicle part. It also shows the relationships between the items.

C3.9.1 The following terminology will be used when referring to the BOM.

- The overall vehicle is broken down into eight (8) systems which are defined in Appendix C-3.
- Systems are made up of Assemblies.
- Assemblies are made up of Parts.

- Parts consist of materials, processes and fasteners.
- Tooling is associated with each process that requires production tooling.

C3.9.2 An example BOM structure is shown below:

- Engine & Drivetrain..... System
 - Engine..... Assembly
 - Differential..... Assembly
 - Housing..... Part
 - Aluminum..... Material
 - Needle Bearing..... Material
 - Sand cast..... Process
 - Die & Core Package #4..... Tooling
 - Machining-Turn..... Process
 - Weld..... Process
 - M6x1.25 Grade 8.8..... Fastener
 - Internals..... Part
 - End Cap..... Part

The BOM must follow the format given above. There must be no other BOM levels added or any removed. Deviations from the structure published will be penalized per Section C.3.17.

C3.9.3 All assemblies, parts and fasteners in the BOM must use a standard numbering convention explained in Appendix C-2.

C3.10 Cost Tables

C3.10.1 All costs in the Cost Report come from the standardized Cost Tables. These tables have been compiled to represent the cost of parts and processes that a manufacturing company could be expected to pay for manufacturing a vehicle at 1000 units per year. Generally, the tabulated value represents ½ of the Manufacturer’s Suggested Retail Price (MSRP) for finished parts. Raw materials, commodities and fasteners also intended to represent the production volume of a company rather than the purchase price of the University teams.

C3.10.2 Requests to alter the cost of goods in the tables because of changing world markets or individual team purchase price will not be approved. The tables are intended to provide a fair, unchanging (within a given competition year) cost for parts and to reduce regional variations in price that may help or hurt certain teams. All teams must use the costs given in the tables. If a team wishes to use any parts, processes or materials not included in the tables an “Add Item Request” must be submitted as per Section C.3.13.

C3.10.3 The tables represent cost based on specific parameters. For example the cost of steel is given per unit of volume (or mass). Likewise, engine costs are listed by displacement and specific power output.

C3.10.4 The following Cost Tables are used

- Materials
- Processes
- Process Multipliers
- Fasteners
- Tooling

- C3.10.5 In general, most items have a cost expressed as a function of one parameter. In cases where more than one parameter is necessary additional categories are listed. For example the power output of the engine has three Categories and for each Category a different expression calculates the cost as a function of the engine displacement, which is the Parameter. The Unit would be cubic centimeters in this case.
- C3.10.6 Process Multipliers are used to modify the standard costs of different operations to account for material and geometric differences in the part. For every process included in the Cost Report the list of process multipliers must be checked to determine if any apply, and if they do their effect on the cost must be included.
- C3.10.7 When adding items from tables to the BOM the comments section should be reviewed thoroughly to understand what is included in the table entry. For example is the spring included in the damper cost? Do the spark plugs come with the engine or are they a separate line item? In cases where the explanation is not clear please contact the Rules Committee for clarification.
- C3.11 Cost Models & Costing Methodology**
The cost models are the underlying methodology and equations that relate the final cost of a part or process to the different operations and goods used in that part. The detailed explanation of the Cost Models and Costing Methodology is included in Appendix C-1 and should be referenced for understanding the use of the Cost Tables.
- C3.12 Make Versus Buy**
Every part on an individual car can be classified as “made” or “bought”. This designation does not necessarily refer to whether a team actually purchased or fabricated a part but is a reflection of how the part must be cost from the Cost Tables.
- Made (or manufactured) parts must be cost as if the company manufacturing the vehicle was going to make the part internally. That is by purchasing raw materials and processing them into a finished product.
 - Bought parts must be cost as if the company manufacturing the vehicle was going to outsource the fabrication of that part. These parts would be received by the vehicle manufacturer in a relatively finished state (see the particular table entry comments field for specific information).
- C3.12.1 The Cost Tables have been constructed as a tradeoff between complexity for the organizers and fairness for the teams. The make versus buy designation enables certain parts to be simplified to a relatively few number of entries. For example some teams may purchase axles but the majority of teams manufacture them. Axles are designated “make” parts so teams that purchase axles **must** cost them as if they had made them starting with the raw materials, in this case probably steel tubing. Made parts can be distinguished because they do not appear explicitly in the Cost Tables or appear with a “*cost as made*” option.
- C3.12.2 If a team genuinely makes a part listed on the table as a bought part they may alternatively cost it as a made part **if and only if** a place holder entry is listed in the tables enabling them to do so. For example, in the category of dampers a “*student built*” entry is included. This line item must be included in the BOM (it has zero cost). Then they must proceed to cost the damper they actually designed and built.

C3.12.3 A table summary of options is given below:

How Table Lists Part	How Team Actually Acquired the Part	
	Team Made	Team Bought
Table Lists Part as "Made", or Part is not Listed in the Tables	Cost as "Made"	Cost as "Made"
Table Lists Part as "Bought"	Team made option NOT in table cost as "Bought". If team made option in table team can choose either "Bought" or "Made"	Cost as "Bought"

C3.12.4 For example a snap ring does not have a “team made” entry in the Cost Tables. A team who made their own would still have to use the table cost based on diameter, even if they could cost it less expensively by buying steel and processing it.

C3.12.5 Any part which is normally purchased that is optionally shown as a made part must have supporting documentation submitted to prove team manufacture. This might include engineering drawings, pictures of machining, etc. Teams found costing bought parts as made parts will be penalized appropriately.

C3.13 Add Item Request

C3.13.1 The costs tables are intended to include all materials, processes and fasteners needed by the teams to accurately reflect the content, manufacture and assembly of their vehicle. However, it will be necessary to add items to the tables to suit individual team requirements. To do this an “Add Item Request” must be submitted to the Rules Committee. After review the item will be added to the tables with the next table update with a cost appropriate to the overall Cost Table framework and spirit of the competition.

The tables will be updated throughout the competition year as required.

C3.13.2 The form should be completely filled out and contains the necessary instructions. Some supporting documentation will be required such as receipts or website links. The Add Item request is the only time receipts will be needed for the Cost Event.

Note: Since all teams work off the same tables once a team requests an item be added to the tables all teams will see the addition. Any team using the newly added item will use the same cost. The identity of the school that made the request will not be published.

C3.14 Report Submission and Deadline

- a. The Cost Report must be submitted in the designated format for each event.
- b. For some events, a printed copy of the report must also be submitted and must be on 8 1/2 inch x 11 inch or A4 size paper, using a 10-point font size or larger.

- c. Submission Address and Deadline – The submission requirements, address and deadline will be published in the appendix or released on the website of the specific competition.

C3.15 Late Submission of Cost Report

It is imperative that the cost judges have the Cost Reports in enough time for proper evaluation. Teams that submit reports late will be penalized 10 points per day late, with a maximum penalty of 80 points. Teams that do not submit a Cost Report will receive negative 100 points for the Cost & Manufacturing Analysis score. Penalties will be applied based on official upload date and time for electronic submission and by post mark for printed submissions.

C3.16 Addenda

- C3.16.1 An addendum that reflects any changes or corrections made after the submission of the Cost Report must be submitted at Registration when the Team registers on-site at the Event. It will not be accepted at any other time or place. The addendum document must follow the template format specified in Appendix C-5. No other format will be accepted.
- C3.16.2 A separate addendum is permitted for every competition a vehicle attends.
- C3.16.3 Any items added to the Cost Report through addenda will be cost at 1.25 times the table cost. Any items removed through addenda will only be credited 0.75 times the table cost.

Note: Late changes to designs impact costs in the real world. Contracts need to be altered, commodity costs can change, cancellation fees may be incurred and information needs to be transmitted to suppliers. The scaling factors for the addenda capture this as well as encourage teams to submit full and accurate information with the initial Cost Report.

C3.17 Cost Report Judging and Penalties Process

- C3.17.1 The following procedure will be used in determining penalties:
 1. Penalty A will be calculated first using procedure C.3.18
 2. Penalty B will then be calculated using alternative procedure C.3.19
 3. The greater of the two penalties will be applied against the cost score
 - a. Penalty A expressed in points will be deducted from the Accuracy score
 - b. Penalty B expressed in dollars will be added to the Adjusted Cost of the vehicle
 4. If no additional points remain to be deducted from the Accuracy score the penalty will be applied using method B against the Adjusted Cost
- C3.17.2 If the alternative penalty is used because no additional accuracy points remain then the highest of the A type penalties will be converted to B type penalties. In effect, the order the penalties are calculated and applied against the team does not matter.
- C3.17.3 Any error that results in a team over reporting a cost in their Cost Report will not be further penalized. For example, when the Cost Report is prepared the thickness of the brake rotors has not yet been determined. The team conservatively costs the rotors as 10mm thick. The final thickness is 8mm and no change is made in the addendum. The team rotor price is higher than necessary but no penalty is applied.

Note: The penalty system is intended to reward accuracy and minimize workload at the competition for students and judges. In most cases the standard points deductions will be made to the accuracy score.

Note: Any instance where a team’s score benefits by an intentional or unintentional error on the part of the students will be corrected on a case by case basis.

C3.18 Penalty Method A- Fixed Point Deductions

C3.18.1 From the Bill of Material, the cost judges will determine if all parts and processes have been included in the analysis. In the case of any omission or error the judges will add a penalty proportional to the BOM level of the error. The following standard points deductions will apply:

- Missing/inaccurate material, process, fastener..... 1 pt.
- Missing/inaccurate part..... 3 pt.
- Missing/inaccurate assembly..... 5 pt.

Note: Each of the penalties listed above supersedes the previous penalty. If a 5 point deduction is given for a missing assembly the missing parts are ignored for Method A. Method B would include the cost of the missing parts in the calculation.

C3.18.2 Differences other than those listed above will be deducted at the discretion of the cost judges.

Examples of errors leading to points deductions:

- Five M6 fasteners listed, six used – 1 pt.
- Three kilograms of steel listed, 4.4 used – 1 pt.
- Bearing carrier face machined, mill operation not included – 1 pt.
- Installation labor for steering wheel missing – 1 pt.
- Upright cost as cast but actual part billet machined – 3 pt.
- Pneumatic shifter not included on BOM – 5 pt.

The penalties above will be deducted from the points awarded for Accuracy of the Cost Report.

C3.19 Penalty Method B – Adjusted Cost Deductions

The alternative penalty will be calculated using the following equation:

$$\text{Penalty} = 2 \times (\text{Table Cost} - \text{Team Reported Cost})$$

The table cost will be calculated from the standard Cost Tables. The penalty calculation will result in a dollar value equal to twice the difference between the team cost and the correct cost for all items in error.

This penalty, if applied, will be made to the Adjusted Cost of the vehicle.

Note: The table costs of all items in error are included in the calculation. A missing assembly would include the price of all parts, materials, processes and fasteners making up the assembly.

C3.20 Penalty Calculation Example

For example the pneumatic shifter was inadvertently left off the Cost Report. As this is an assembly the standard error is 5 points. The cost of all air shifter parts and processes from the Cost Tables is \$500. This means the total penalty cost is \$1000. To see which is greater, 5 points or \$1000, the dollar penalty needs to be converted to points by reference to the Cost Points formula:

$$\text{Points} = \frac{40 \times [(P_{\text{max}})/(P_{\text{your}}) - 1]}{[(P_{\text{max}})/P_{\text{min}}] - 1}$$

Substitute the cost of the vehicle (P_{your}) with \$15,000 while the minimum vehicle cost (P_{min}) was \$10,000. The maximum vehicle cost (P_{max}) was \$50,000. Calculating the points equivalent for this dollar amount yields 2.5 points. This is less than the standard penalty. In this case the 5 points would be deducted from the Accuracy score.

If the team had made many small errors and had no more accuracy points available then the \$1000 would be added to the team's adjusted cost.

C3.21 Discussion at the Competition

C3.21.1 At this discussion, the Cost Judges will:

- a. Review whether the specification of the vehicle in the Cost Report accurately reflects the vehicle brought to the Competition
- b. Review the manufacturing feasibility of the vehicle
- c. Assess penalties for missing or incorrect information in the Cost Report compared to the vehicle presented at inspection.

C3.21.2 The team must present their vehicle at the designated time to the Cost Judges for review of the Cost Report. Teams that miss their cost appointment will potentially lose all cost points for that day. The schedule for these appointments will be in the registration packets and/or posted on the website.

C3.22 Cost Report Exempt Items

C3.22.1 Finishes

The car will be considered to be shipped as primed or gel coated and a cost recorded. Any finishes (paint, polish, etc.) that are only used to beautify need not be costed. Preservative finishes intended to protect the appearance or function of a part for an extended period of time must be costed (labor and material included).

C3.22.2 Fire Extinguisher and Suppression System

Hand held fire extinguishers are not allowed on the vehicle (See Rule B.17.2 "Fire Extinguishers"), but if the car has an on-board fire suppression system, it is not required to be costed.

C3.22.3 Tires and Wheels

Only one set of tires and wheels needs to be included in the Cost Report. The tires and wheels that are declared as dry tires per rule B.6.4 "Tires" must be the tires included in the Cost Report, and must be the tires on the car during the Cost Event judging. Other tires that will be potentially used at the competition (i.e. rain tires) do not need to be included in the Cost Report.

C3.22.4 Transponders, Video and Radio Systems

Transponders, video and radio systems, need not be included in the Cost Report.

C3.22.5 *Data Acquisition Systems*

*Data acquisition systems must be included in the Cost Report using the published table costs. This includes display screens, control modules and all sensors. The table costs for control modules and screens have been set to match an equivalent product **without** the data acquisition functionality. In essence, "stand-alone" data acquisition systems excluding sensors and wiring will have no influence on vehicle cost. Systems where there are driver displays or other vehicle control functionality will have the cost of those features included in the total vehicle cost.*

In summary, all data acquisition systems, sensors and wiring must be included in the Cost Report using the Cost Table prices.

C3.23 Exchange Rates & Unit Systems

The currency of the Cost Report will be referred to as dollars. Since all items have a cost from the Cost Tables the actual currency unit is irrelevant.

- C3.23.1 All Cost Tables are presented using metric units. The tables do not differentiate between parts designed in metric and US systems of measure. For example a ¼ bolt is simply input as a 6.35mm bolt. Tubing with a wall thickness of 0.035 inches is input as 0.889mm tubing. All sizes are assumed to be standard for the part being cost and no surcharge applies for any size, even if the size is non-standard. For example a team makes a custom 6.112mm bolt which took several hours of student time. However, this bolt is chosen from the Cost Tables and is less than one dollar. The assumption is in high volume production these bolts would be purchased in bulk.
- C3.23.2 The comment section for each material, process or fastener may, at the student's discretion, refer to the specific part by actual local designation. For example a 6.35mm bolt is cost but the comments would say "¼ inch A-arm bolt".
- C3.23.3 Because the Cost Report reflects a production cost for 1000 units per year all material and commodity sizes are assumed to be available for the necessary volume without cost penalty.

C3.24 Cost Application

The Formula SAE Cost Application (FCA) is a software application written to assist teams with compiling, preparing and submitting their Cost Report.

- 3.21.1 The download for the Cost Application along with additional information such as users manuals and installation instructions can be found on the SAE Website.
- 3.21.2 The Cost Application requires an authentication number for data entered by the team to be synchronized with the FSAE server. This authentication number will usually be provided during the competition registration. If not, then (1) For the North American competitions go to the "Dedicated Cost Website" found on the "Rules and Important Documents" page of the Formula SAE Website (2) For competitions outside North America consult the Individual competition website.. One authentication number will be used for all events within a year. It is the team's responsibility to protect the security of this number as it controls access to the proprietary team data entered into the database.

C3.25 Examples

Examples will be posted to the SAE website

ARTICLE 4: PRESENTATION EVENT**C4.1 Presentation Event Objective – Business Case**

- C4.1.1 The objective of the presentation event is to evaluate the team's ability to develop and deliver a comprehensive business case that will convince the executives of a corporation that the team's design best meets the demands of the amateur, weekend competition market, including Sports Car Club of America (SCCA) Solo, and that it can be profitably manufactured and marketed. (See also A.1.2)
- C4.1.2 The judges should be treated as if they were executives of a corporation.
- C4.1.3 Teams should assume that the "executives" represent different areas of a corporate organization, including engineering, production, marketing and finance, and thus may not all be engineers.

C4.1.4 Presentations will be evaluated on the contents, organization and visual aids as well as the presenters' delivery and the team's response to questions.

C4.1.5 The presentation must relate to the car entered into the competition although the actual quality of the prototype itself will not be considered as part of the presentation judging.

C4.2 Presentation Schedule

C4.2.1 Presentations will be made on the static events day. Presentation times will be scheduled by the organizers and either, or both, posted in advance on the competition website or released during on-site registration.

C4.2.2 Teams that fail to make their presentation during their assigned time period will receive zero (0) points for the event.

C4.3 Presentation Format

C4.3.1 One or more team members will give the presentation to the judges.

C4.3.2 All team members who will give any part of the presentation, or who will respond to the judges' questions, must be in the podium area when the presentation starts and must be introduced to the judges. Team members who are part of this "presentation group" may answer the judge's questions even if they did not speak during the presentation itself.

C4.3.3 Presentations are limited to a maximum of ten (10) minutes. The judges will stop any presentation exceeding ten minutes.

C4.3.4 The presentation itself will not be interrupted by questions. Immediately following the presentation there will be a question and answer session of up to five (5) minutes.

C4.3.5 Only judges may ask questions. Only team members who are part of the "presentation group" may answer the judges' questions.

C4.4 Data Projection Equipment

C4.4.1 Projection equipment is not provided by the organizers.

C4.4.2 Teams planning to use data projectors, or any type of projectors, as part of their presentation are responsible for bringing, or otherwise arranging for, their own projection equipment.

4.5 Evaluation Criteria

C4.5.1 Presentations will be evaluated on content, organization, visual aids, delivery and the team's response to the judges' questions. The scoring criteria are detailed in Appendix C-6 "Presentation Judging".

C4.5.2 The criteria are applied only to the team's presentation itself. The team that makes the best presentation, regardless of the quality of their car, will win the event.

C4.6 Scoring Formula

C4.6.1 The Presentation Events score is based on the average of the judges' scores.

C4.6.2 There is a maximum of fifty (50) points from the Presentation Judging Form.

$$\text{PRESENTATION SCORE} = 75 \times P_{\text{your}}/P_{\text{max}}$$

Where:

“Pmax” is the highest score awarded to any team

“Pyour” is the score awarded to your team

- C4.6.3 It is intended that the scores will range from near zero (0) to seventy-five (75) to provide good separation.
- C4.6.4 The Presentation Event Captain may at his/her discretion; normalize the scores of different judging teams.

C4.7 Presentations without a completed car

Teams that are unable to bring a completed vehicle to the competition may participate in the Presentation Event and will receive a score for that event.

Note: Participating in the Presentation event without bringing a vehicle to the competition will not affect the status of the car you have under construction at your school. When you finish it and bring it to a competition it will still be a first year vehicle under Rules A6.6 and A6.8

ARTICLE 5: DESIGN EVENT

C5.1 Design Event Objective

- C5.1.1 The concept of the design event is to evaluate the engineering effort that went into the design of the car and how the engineering meets the intent of the market.
- C5.1.2 The car that illustrates the best use of engineering to meet the design goals and the best understanding of the design by the team members will win the design event.

Comment: Teams are reminded that FSAE is an engineering design competition and that in the Design Event; teams are evaluated on their design. Components and systems that are incorporated into the design as finished items are not evaluated as a student designed unit, but are only assessed on the team’s selection and application of that unit. For example, teams that design and fabricate their own shocks are evaluated on the shock design itself as well as the shock’s application within the suspension system. Teams using commercially available shocks are evaluated only on selection and application within the suspension system.

C5.2 Design Report – Submission Requirements

- C5.2.1 Design Report - Judging will start with a Design Review before the event. The principal document submitted for Design Judging is a Design Report.
- C5.2.2 The Design Report must not exceed eight (8) pages, consisting of not more than four (4) pages of text, three (3) pages of drawings (see C5.3, “Vehicle Drawings”) and one (1) optional page containing content to be defined by the team (photo’s, graphs, etc...).
- C5.2.3 The document should contain a brief description of the vehicle with a discussion of any important design features and vehicle concepts. Include a list of different analysis and testing techniques (FEA, dynamometer testing, etc.). Evidence of this analysis and back-up data should be brought to the competition and be available, on request, for review by the judges.

- C5.2.4 These documents will be used by the judges to sort teams into the appropriate design groups based on the quality of their review.

Comment: Consider your Design Report to be the “resume of your car”.

C5.3 Vehicle Drawings

- C5.3.1 The Design Report must include one set of 3 view drawings showing the vehicle, from the front, top, and side.
- C5.3.2 Each drawing shall appear on a separate page. The drawings can be manual or computer generated.
- C5.3.3 Photos should be placed on the optional page and will not be counted as drawings.

C5.4 Design Spec Sheet – Submission Requirements

- C5.4.1 Design Spec Sheet – A completed FSAE Design Spec Sheet must be submitted.
- C5.4.2 The FSAE Design Spec Sheet template can be found on the FSAE website at: <http://www.sae.org/students/fsae-designspecs.xls>. Do not alter or re-format the template prior to submission.
- C5.4.3 The design judges realize that final design refinements and vehicle development may cause the submitted figures to diverge slightly from those of the completed vehicle. For specifications that are subject to tuning, an anticipated range of values may be appropriate.
- C5.4.4 The Design Report and the Design Spec Sheet, while related documents, should stand alone and be considered two (2) separate submissions. Two separate file submissions are required.

C5.5 Design Report and Design Spec Sheet Formats

- C5.5.1 The Design Report must be submitted electronically in Adobe Acrobat® Format (*.pdf file). This document must be a single file (text, drawings, and optional content all inclusive).
- C5.5.2 The Design Report file must be named as follows:
carnumber_schoolname.pdf using the FSAE assigned car number and the complete school name, e.g. 001_University of SAE.pdf
- C5.5.3 Design Spec Sheets must be submitted electronically in Microsoft Excel® Format (*.xls file). The format of the Spec Sheet MUST NOT be altered.
- C5.5.4 Similar to the Design Report, the Design Spec Sheet file must be named as follows:
carnumber_schoolname_specs.xls using the FSAE assigned car number and the complete school name, e.g. 001_University of SAE_spec.xls

WARNING – Failure to exactly follow the above submission requirements may result in exclusion from the Design Event. If your files are not submitted in the required format or are not properly named then they cannot be included in the documents provided to the design judges and your team will be excluded from the event.

C5.6 Excess Size Design Reports

If a team submits a Design Report that exceeds four (4) pages of text, three (3) pages of drawing and one (1) optional page, then only the first four pages of text, three pages of drawings and first optional page will be read and evaluated by the judges. Note: If included, cover sheets and tables of contents will count as text pages.

C5.7 Student Activity Disclosure – Required Submission

C5.7.1 A “Student Activity Disclosure Form” detailing the distribution of the design, manufacturing and assembly of the vehicle between members of the team and non-members must be submitted. The standard Disclosure Form available on the FSAE website must be used. The Disclosure Form is a required Design Document and subject to the submission deadlines and penalties found in Rule C5.8 “Submission Deadlines” and Rule C5.9 “Penalty for Late Submission or Non-submission”. The Student Activity Disclosure Form is posted on the FSAE website.

C5.7.2 Definitions: For the purposes of completing the Student Activity Disclosure Form the following definitions will apply:

C5.7.3 Team Designed – “Team Designed” states that the team designed the component to be manufactured from raw materials to meet a project goal and/or to comply with a requirement of the FSAE Rules. Designed components may incorporate commercially manufactured parts, e.g. bearings, fasteners, gears, sensors, electronic components, etc. provided that the final “design” reflects the thinking of the team and was designed to meet a team defined purpose. Remanufacturing a component to a design developed by a previous team is not considered to be a “design” by the current team.

C5.7.4 Team Manufactured – “Team Manufactured” states that the team members performed the actual hands-on work of fabricating the component from raw materials, or subcomponents, through the use of one or more fabrication processes including, but not limited to: bonding, casting, cutting, drilling, hardening, laminating, machining, polishing, riveting and welding. Any components produced by non-team members, including school machinists or welders, outside machinists or welders, sponsors or others are not considered to have been “manufactured” by the team. Please note that assembling commercially available parts alone, without “manufacturing” any part from raw materials is assembling **not** manufacturing.

C5.7.5 Team Assembled – “Team Assembled” states that the team members assembled the component, or section of the vehicle, from smaller pieces and/or subcomponents through the use of one or more assembly and fastening processes including, but not limited to: bolting, gluing, screwing, welding and wiring.

C5.8 Submission Deadlines

C5.8.1 The Design Report, the Design Spec Sheets and the Student Activity Disclosure Form must arrive at the specified e-mail address by the date shown in the Action Deadlines for the competition your team is entering. E-mail the Design Report and forms to the address provided in the appendix or published on the competition website.

C5.7.2 The three required submissions for the Design Event must be e-mailed as separate files.

C5.7.3 Teams will receive confirmation of receipt via email and/or the event website once report is reviewed for accuracy. Teams should have a printed copy of this reply available at the competition as proof of submission in the event of discrepancy.

C5.8 Penalty for Late Submission or Non-submission

Teams that do not submit a Design Report, a Design Spec Sheet and a *Student Activity Disclosure Form* by the specified deadline will not compete in the design event, and will receive zero (0) points for design.

C5.9 Penalty for Unsatisfactory Submissions

At the discretion of the judges, teams that submit a Design Report or a Design Spec Sheet which is deemed to be unsatisfactory, will also not compete in the design event, but may receive between five (5) and twenty (20) points for their efforts.

C5.10 Design Event – Vehicle Condition

C5.10.1 Cars must be presented for design judging in finished condition, i.e. fully assembled, complete and ready-to-run.

C5.10.2 The judges will not evaluate any car that is presented at the design event in what they consider to be an unfinished state.

C5.10.3 Unfinished cars that are refused judging will receive zero (0) points for design.

C5.10.4 Point penalties may be assessed for cars with obvious preparation issues, e.g. notably loose or missing fasteners.

Note: Cars can be presented for design judging without having passed technical inspection, and even if final tuning and setup is in progress.

C5.11 Judging Criteria

C5.11.1 The design judges will evaluate the engineering effort based upon the team's Design Report, Spec Sheet, *Student Activity Disclosure Form*, responses to questions and an inspection of the car.

C5.11.2 The design judges will inspect the car to determine if the design concepts are adequate and appropriate for the application (relative to the objectives set forth in the rules and the specific design goals expressed by the team).

C5.11.3 It is the responsibility of the judges to deduct points on the design judging form, if the team cannot adequately explain the engineering and construction of the car.

C5.12 Judging Sequence

C5.12.1 The actual format of the design event may change from competition to competition and year to year as determined by the organizing body.

C5.12.2 All Formula SAE organizing bodies reserve the right to organize Design Judging into one, two or three steps at their sole discretion.

C5.12.3 Three step Design Judging is typically organized as follows:

1. Initial judging of all vehicles
2. Semi- final judging of the top 10 to 20 vehicles
3. Final judging ranking the top 4 to 8 vehicles.

C5.13 Scoring

C5.13.1 Scoring may range from 0 to 150 points at the judge's discretion.

C5.13.2 The judges may at their discretion award the highest placing team less than 150 points.

C5.14 Support Material

Teams may bring with them to the Design Event any photographs, drawings, plans, charts, example components or other materials that they believe are needed to support the presentation of the vehicle and the discussion of their development process.

C5.15 Second Year Cars - Penalties for Insufficient Redesign

C5.15.1 Penalties for insufficient redesign are in effect at Formula SAE Australasia, Formula SAE Brazil, Formula SAE Italy, and Formula Student.

C5.15.2 The judges will deduct fifty (50) points from the final design score for cars without a new frame. (see Rule A.6.9) An additional thirty (30) points may be deducted if the photographic and other supporting documentation fails to show that the remaining parts of the vehicle have been significantly changed (e.g. the intake manifold is obviously the same or it is obvious that the old suspension was simply bolted to a new frame, or none of the team members show an understanding of the design of various components).

C5.15.3 If the new frame is similar to last years, it is advisable to bring along evidence of the change (bringing along the old frame is not a bad idea).

C5.15.4 Second year cars are prohibited at the North American FSAE competitions. (See Rule A.6.7)

**APPENDIX C – 1
COST MODELS AND COST METHODOLOGY**

Please see SAE Website for Appendix C-1

**APPENDIX C – 2
STANDARD PART NUMBERING**

Please see SAE Website for Appendix C-2

**APPENDIX C – 3
ORGANIZED LIST OF SYSTEMS & ASSEMBLIES**

Please see SAE Website for Appendix C-3

**APPENDIX C – 4
POWER TOOL PACKAGE ENVELOPES**

Please see SAE Website for Appendix C-4

**APPENDIX C – 5
2011 FSAE COST EVENT ADDENDUM**

School: _____ Car Number: _____

(Please indicate decreases using bracketed numbers.)

	Section	Original Reported Total	New Reported Total	Difference	Cost Judge Initials
1					
2					
3					
4					
5					
6					
7					
8					

TOTAL VEHICLE

Summary of differences listed above.
fully detailed Costed Bill of Material for

\$	\$	\$
----	----	----

Attach changes.

1
2
3
4
5
6
7
8

Accepted by: _____	Entered by: _____
Date: _____	Date/Time: _____

Addendums will be accepted only at the time of registration on-site at the competition!
These forms will then be forwarded to the cost judges the morning of the cost event.

APPENDIX C – 6
PRESENTATION JUDGING

SCHOOL _____ CAR NUMBER _____

Score the following categories on the basis of 0-10 points each according to the following scale (any number or fraction along this scale may be used).

- 0.0 = inadequate or no attempt
2.5 = attempted but below expectation
5 = average or expected
7.5 = above average but still lacking
10 = excellent, perfectly meets intent

_____ CONTENT: Were the concepts presented appropriate and adequate to explain how the car meets the intent of the customer? Were enough technical details presented without being boring?
_____ ORGANIZATION: Were the concepts presented in a logical order progressing from basic concept and showing how the engineering accomplished the concept? Was it clear to the audience what was to be presented and what was coming next? Were distinct introduction and overviews as well as summary and conclusions given?
_____ VISUAL AIDS: Were visual aids used or clear visual references made to the car? Were the illustrations visible for all of the audience?
_____ DELIVERY: Did the presenter speak in a clear voice? Did the presenter show enthusiasm and promote confidence in the technical aspects? Did he maintain eye contact?
_____ QUESTIONS: Did the answer illustrate that the team fully understood the question? Is there doubt that the team understood the answer? Did the team promote complete confidence in their response to the questions?
_____ TOTAL = PRESENTATION POINTS (50 points maximum)

COMMENTS: _____

APPENDIX C – 7
DESIGN JUDGING SCORE SHEET

The Design Event Score Sheet is posted on the FSAE website under “Rules and Important Documents”.

Teams are advised to thoroughly read all the documents related to the Design Event that is posted on the FSAE website.

**2011 Formula SAE Rules
PART D – DYNAMIC EVENT REGULATIONS**

ARTICLE 1: DYNAMIC EVENTS AND MAXIMUM SCORES

The maximum scores in the dynamic events are:

Acceleration	75 points
Skid Pad	50 points
Autocross	150 points
Fuel Economy	100 points
<u>Endurance</u>	<u>300 points</u>
Total	675 points

D1.1 Vehicle Integrity and Disqualification

D1.1.1 During the Dynamic Events, the mechanical integrity of the vehicle must be maintained.

D1.1.2 Any vehicle condition that could compromise vehicle integrity, or could compromise the track surface or could pose a potential hazard to participants, e.g. damaged suspension, brakes or steering components, fluid leaks, dragging bodywork, or lost or loose body panels, will be a valid reason for exclusion by the official until the problem is rectified.

Note: If this happens during the Endurance Event, it means disqualification from the heat.

ARTICLE 2: WEATHER CONDITIONS

The organizer reserves the right to alter the conduct and scoring of the competition based on weather conditions.

ARTICLE 3: RUNNING IN RAIN

D3.1 Operating Conditions

The following operating conditions will be recognized at Formula SAE:

D3.1.1 Dry – Overall the track surface is dry.

D3.1.2 Damp – Significant sections of the track surface are damp.

D3.1.3 Wet – The entire track surface is wet and there may be puddles of water.

D3.1.4 Weather Delay/Cancellation – Any situation in which all, or part, of an event is delayed, rescheduled or canceled in response to weather conditions.

D3.2 Decision on Operating Conditions

The operating condition in effect at any time during the competition will be decided by the competition officials.

D3.3 Notification

If the competition officials declare the track(s) to be "Damp" or "Wet",

- i. This decision will be announced over the public address system, and
- ii. A sign with either "Damp" or "Wet" will be prominently displayed at both the starting line(s) or the start-finish line of the event(s), and the entry gate to the "hot" area.

D3.4 Tire Requirements

The operating conditions will determine the type of tires a car may run as follows:

- D3.4.1 Dry – Cars must run their Dry Tires, except as covered in Rule D.3.8.2.
- D3.4.2 Damp – Cars may run either their Dry Tires or Rain Tires, at each team’s option.
- D3.4.3 Wet – Cars must run their Rain Tires.

D3.5 Event Rules

All event rules remain in effect.

D3.6 Penalties

All penalties remain in effect.

D3.7 Scoring

No adjustments will be made to teams' times for running in "Damp" or "Wet" conditions. The minimum performance levels to score points may be adjusted if deemed appropriate by the officials.

D3.8 Tire Changing

D3.8.1 During the Acceleration, Skid-Pad or Autocross Events:

Within the provisions of Rule D.3.4 above, teams may change from Dry Tires to Rain Tires or vice versa at any time during those events at their own discretion.

D3.8.2 During the Endurance Event:

Teams may change from Dry to Rain Tires or vice versa at any time while their car is in the staging area inside the "hot" area.

All tire changes after a car has received the "green flag" to start the Endurance Event shall take place in the Driver Change Area.

- (a) If the track was "Dry" and is declared "Damp":
 - Teams may start on either Dry or Rain Tires at their option.
 - Teams that are on the track when it is declared "Damp", may elect, at their option, to pit in the Driver Change Area and change to Rain Tires under the terms spelled out below in "Tire Changes in the Driver Change Area".
- (b) If the track is declared "Wet":
 - A Red Flag will be shown at the Start/Finish Line and all cars will enter the Driver Change Area.
 - Those cars that are already fitted with "Rain" tires will be allowed re-start without delay subject to the discretion of the Event Captain/Chief Marshall.
 - Those cars without "Rain" tires will be required to fit them under the terms spelled out below in "Tire Changes in the Driver Change Area". They will then be allowed to re-start at the discretion of the Event Captain/Chief Marshall.
- (c) If the track is declared "Dry" after being "Damp" or "Wet":
 - The teams will NOT be required to change back to “Dry” tires.

- (d) Tire Changes at Team's Option:
- Within the provisions of Rule D.3.4 above and Rule D.3.8.2(b) above, a team will be permitted to change tires at their option.
 - If a team elects to change from “Dry” to “Rain” tires, the time to make the change will NOT be included in the team’s total time.
 - If a team elects to change from “Rain” tires back to “Dry” tires, the time taken to make the change WILL be included in the team’s total time for the event, i.e. it will not be subtracted from the total elapsed time. However, a change from “Rain” tires back to “Dry” tires will not be permitted during the driver change.
 - To make such a change, the following procedure must be followed:
 - Team makes the decision,
 - Team has tires and equipment ready near Driver Change Area,
 - The team informs the Event Captain/Chief Marshall they wish their car to be brought in for a tire change,
 - Officials inform the driver by means of a sign or flag at the checker flag station,
 - Driver exits the track and enters the Driver Change Area in the normal manner.
- (e) Tire Changes in the Driver Change Area:
- Per Rule D.8.11.2, no more than three people for each team may be present in the Driver Change Area during any tire change, e.g. a driver and two crew or two drivers and one crew member.
 - No other work may be performed on the cars during a tire change.
 - Teams changing from "Dry" to "Rain" tires will be allowed a maximum of ten (10) minutes to make the change.
 - If a team elects to change from "Dry" to "Rain" tires during their scheduled driver change, they may do so, and the total allowed time in the Driver Change Area will be thirteen (13) minutes.
 - The time spent in the driver change area of less than 10 minutes without driver change, or 13 minutes with driver change, will not be counted in the team's total time for the event. Any time in excess of these times will be counted in the team's total time for the event.

ARTICLE 4: DRIVER LIMITATIONS

D4.1 Three Event Limit

An individual team member may not drive in more than three (3) events.

- D4.1.1 The Fuel Economy Event is considered a separate event although it is conducted simultaneously with the Endurance Event.

D4.2 Single Heat Limit

An individual may not drive in both heats of any event. It is the team’s option to participate in any event.

- D4.2.1 The team may forfeit their second heat in any performance event.

Note: At competitions where Endurance and Fuel Economy is run with one (1) heat a minimum of four (4) drivers are required to participate in all heats of the dynamic events. At competitions where Endurance and Fuel Economy is run with two (2) heats a minimum of five (5) drivers are required to participate in all heats of the dynamic events.

ARTICLE 5: ACCELERATION EVENT

D5.1 Acceleration Objective

The acceleration event evaluates the car's acceleration in a straight line on flat pavement.

D5.2 Acceleration Procedure

Course Layout – The acceleration course length will be 75 m (82 yards) from starting line to finish line. The course will be at least 4.9 m (16 ft) wide as measured between the inner edges of the bases of the course edge cones. Cones are placed along the course edges at intervals of about 5 paces (roughly 20 feet). Cone locations are not marked on the pavement.

D5.2.1 Staging - The foremost part of the car will be staged at 0.30 m (11.8 inches) behind the starting line. Cars will accelerate from a standing start.

D5.2.2 Starting - A green flag will be used to indicate the approval to begin, however, timing starts only when the vehicle crosses the starting line as measured by the timing system.

D5.2.3 Second Run Option - A driver has the option to make a second run immediately after his/her first run.

D5.3 Acceleration Heats

D5.3.1 There will be two (2) heats. Each heat must have a different driver and each driver can have two (2) runs.

D5.3.2 Starting order will be based upon time of arrival to the staging area.

D5.3.3 Heat one (1) and heat two (2) will not be run sequentially, but simultaneously. Heat 1 drivers will have starting priority over heat 2 drivers.

D5.4 Tire Traction – Limitations

Special agents that increase traction may not be added to the tires or track surface and “burnouts” are not allowed.

D5.5 Acceleration Scoring

The acceleration score is based upon the corrected elapsed time. Elapsed time will be measured from the time the car crosses the starting line until it crosses the finish line.

D5.6 Acceleration Penalties

D5.6.1 Cones Down Or Out (DOO)

A two (2) second penalty will be added for each DOO (including entry and exit gate cones) that occurred on that particular run to give the corrected elapsed time.

D5.6.2 Off Course

An Off Course (OC) will result in a DNF for that run.

D5.7 Did Not Attempt

Cars that have not run by the end of the event (determined by the organizer) will receive a Did Not Finish (DNF).

D5.8 Acceleration Scoring Formula

D5.8.1 The score for the acceleration event is spread between zero (0) and seventy-five (75) based upon the elapsed time.

D5.8.2 The following equation is used to determine the scores for the event:

$$\text{ACCELERATION SCORE} = 71.5 \times \frac{(5.8/T_{\text{your}}) - 1}{(5.8/T_{\text{min}}) - 1} + 3.5$$

Where:

T_{your} is the best corrected elapsed time for the team including penalties.

T_{min} is the elapsed time of the fastest car.

D5.8.3 In the above equation, the first term on the right hand side is “performance” points”, while the second term represents “completion points,” or the minimum score for having successfully completed the event.

DNF = zero (0) points

D5.8.4 The maximum acceptable acceleration time is 5.8 seconds corresponding to an average speed of 46.55 km/hr.

D5.8.5 Negative “performance” points will not be given. However, 3.5 points will be given for a car that completes a run, even if T_{your} exceeds 5.8 seconds.

ARTICLE 6: SKID-PAD EVENT

D6.1 Skid-Pad Objective

The objective of the skid-pad event is to measure the car’s cornering ability on a flat surface while making a constant-radius turn.

D6.2 Skid-Pad Heats

D6.2.1 Each car may compete in two heats. Each heat must have a different driver, and each driver may have two (2) runs.

D6.2.2 Two separate skid-pad locations may exist. If there are two (2) skid-pads, one driver must make both his runs on one skid-pad (Skid-Pad 1) and the other driver must make both his runs on the other skid-pad (Skid-Pad 2).

D6.2.3 If there is only one skid-pad location then both Heat one (1) and Heat two (2) will be run on the same skid-pad.

D6.3 Skid-Pad Heat Priority

There will be no distinction between Heat one (1) and Heat two (2) and there will be no particular starting order. Heat one (1) drivers will have a starting priority over Heat two (2) drivers. Cars which have not run by the event closing (determined by the organizer) will receive a DNF for the event.

D6.4 Skid-Pad Layout

There will be two (2) pairs of concentric circles in a figure of eight pattern. The centers of these circles will be 18.25 m (59.88 feet) apart. The inner circles will be 15.25 m (50.03 feet) in diameter, and the outer circles will be 21.25 m (69.72 feet) in diameter. The driving path will be the 3.0 m (9.84 feet) path between the inner and outer circles. The cars will enter and exit through gates on a 3.0 m wide path that is tangential to the circles where they meet.

The line between the centers of the circles defines the start/stop line. A lap is defined as traveling around one (1) of the circles from the start/stop line and returning to the start/stop line.

FSAE SKIDPAD LAYOUT

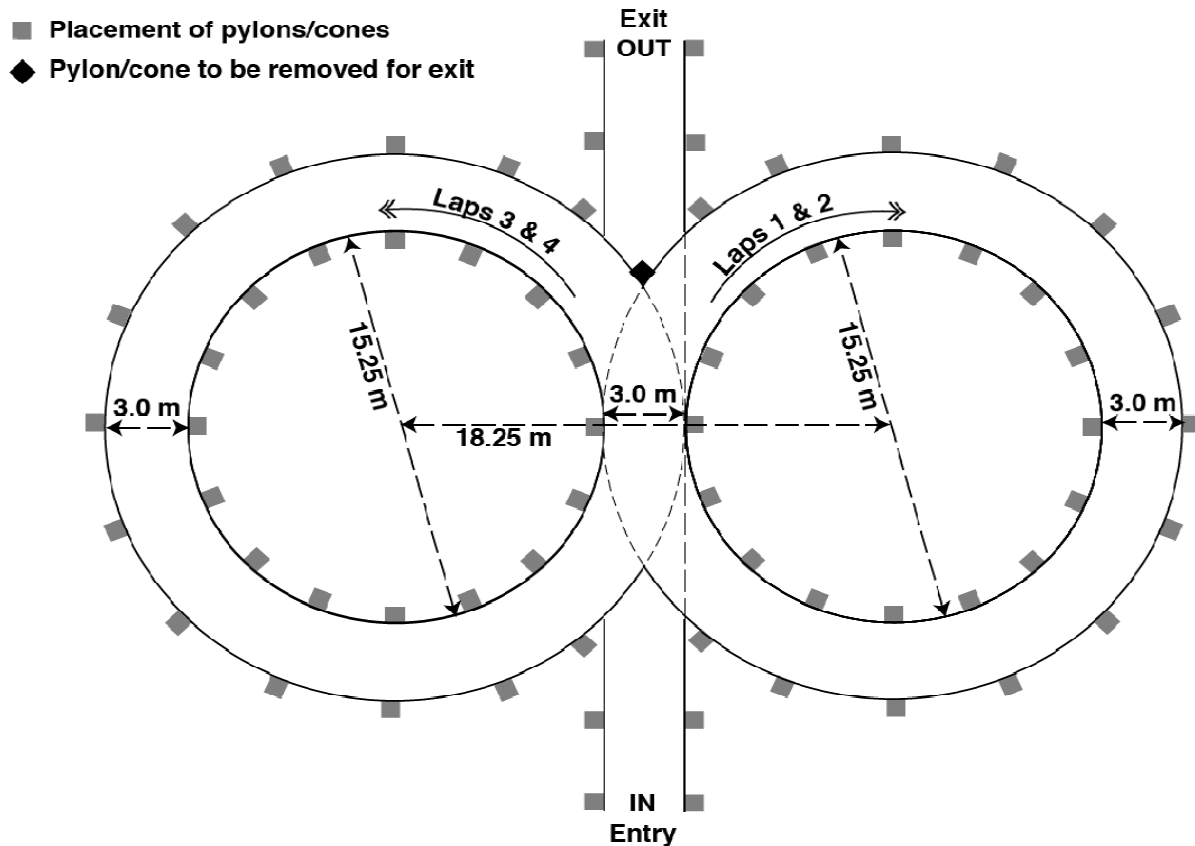

D6.5 Skid-Pad Layout – Marking

- D6.5.1 Sixteen (16) pylons will be placed around the inside of each inner circle thirteen (13) pylons positioned around the outside of each outer circle in the pattern shown in the FSAE skid pad layout diagram.
- D6.5.2 Each circle will be marked with a chalk line, inside the inner circle and outside the outer circle, i.e. not on the driving path.
- D6.5.3 Additional pylons will establish the required entry and exit gates. Also, a cone will be placed in the middle of the exit gate to prevent unintended exits until the finish lap.

Note: The diagram in section D6.4 shows the circles for cone placement, not for course marking. Chalk lines are marked on the opposite side of the cones, i.e. not in the driving path.

D6.6 Skid-Pad Procedure

The cars will enter perpendicular to the figure eight and will take one full lap on the right circle to establish the turn. The next lap will be on the right circle and will be timed. Immediately following the second lap, the car will enter the left circle for the third lap. The fourth lap will be on the left circle and will be timed. Immediately upon finishing the fourth lap, the car will exit the track. The car will exit at the intersection moving in the same direction as entered. A driver has the option to take a second run immediately after the first.

D6.7 Skid-Pad Penalties

The elapsed time for the right and left circle will be averaged together after the following penalties have been assessed.

D6.7.1 Cones Down Or Out (DOO)

A penalty of 0.25 seconds will be added to the time for every cone that is knocked “down or out” (including gate cones).

D6.7.2 Off Course

Cars that spin-out can continue as long as they have not gone off course. Cars going off course will be classified as DNF.

D6.7.3 Incorrect Laps

Cars that do not follow D.6.6 above, i.e. run an incorrect number of laps or run the laps in the wrong sequence will be classified as DNF.

D6.8 Skid-Pad Scoring

D6.8.1 The skid-pad score is computed based upon the lateral acceleration capability. Lateral acceleration (typically referred to as G’s) is computed from $2.012 \text{ diameter}/t^2$. A diameter of 17.10 m will be assumed in computing lateral G’s.

D6.8.2 If there are two separate skid-pad locations, then the score will be based on the best run from either skid-pad.

D6.8.3 The following equation is used to determine the scores for the skid-pad event:

$$\text{SKID PAD SCORE} = 47.5 \times \frac{(6.184/T_{\text{your}})^2 - 1}{(6.184/T_{\text{min}})^2 - 1} + 2.5$$

Where:

T_{your} is the average of the left and the right timed laps on your best run including penalties.

T_{min} is the elapsed time of the fastest car

D6.8.4 The first term on the right-hand side of the equation represent “performance points,” while the second term represents “completion points,” or the minimum score for having successfully completed the event.

D6.8.5 The minimum acceptable lateral acceleration to earn “performance” points is 0.90 G’s corresponding to 6.184 seconds per circle. Negative “performance” points will not be given. However, 2.5 points will be given if a car that completes a run that exceeds 6.184 seconds per circle AND is not classified as a DNF.

ARTICLE 7: AUTOCROSS EVENT**D7.1 Autocross Objective**

The objective of the autocross event is to evaluate the car's maneuverability and handling qualities on a tight course without the hindrance of competing cars. The autocross course will combine the performance features of acceleration, braking, and cornering into one event.

D7.2 Autocross Course Specifications & Speeds

D7.2.1 The following standard specifications will suggest the maximum speeds that will be encountered on the course. Average speeds should be 40 km/hr (25 mph) to 48 km/hr (30 mph).

Straights: No longer than 60 m (200 feet) with hairpins at both ends (or) no longer than 45 m (150 feet) with wide turns on the ends.

Constant Turns: 23 m (75 feet) to 45 m (148 feet) diameter.

Hairpin Turns: Minimum of 9 m (29.5 feet) outside diameter (of the turn).

Slaloms: Cones in a straight line with 7.62 m (25 feet) to 12.19 m (40 feet) spacing.

Miscellaneous: Chicanes, multiple turns, decreasing radius turns, etc. The minimum track width will be 3.5 m (11.5 feet).

D7.2.2 The length of each run will be approximately 0.805 km (1/2 mile) and the driver will complete a specified number of runs.

D7.2.3 The organizers reserve the right to run the Autocross Event on courses of different length.

D7.2.4 The organizers reserve the right to deviate from the standard specifications when they determine it is appropriate given the characteristics of a particular competition site.

D7.3 Autocross Procedure

D7.3.1 There will be two (2) Autocross-style heats, with each heat having a different driver. Two (2) timed laps will be run (weather and time permitting) by each driver and the best lap time will stand as the time for that heat.

D7.3.2 The car will be staged such that the front wheels are 6 m (19.7 feet) behind the starting line. The timer starts only after the car crosses the start line.

D7.3.3 There will be no particular order of the cars to run each heat but a driver has the option to take a second run immediately after the first.

D7.3.4 The organizer will determine the allowable windows for each heat and retains the right to adjust for weather or technical delays. Cars that have not run by the end of the heat will be disqualified for that heat.

D7.4 Autocross Penalties

The cars are judged on elapsed time plus penalties. The following penalties will be added to the elapsed time:

D7.4.1 Cone Down or Out (DOO)

Two (2) seconds per cone, including any after the finish line.

D7.4.2 Off Course (OC)

- a. An “off course” occurs when the vehicle has all four (4) wheels outside the course boundary as indicated by (a) cones, (b) edge marking or (c) the edge of the paved surface. Where more than one boundary indicator is used on the same course, at any given point the narrowest track will be used when determining off course penalties.
- b. When an OC occurs, the driver must reenter the track at or prior to the point of exit or a twenty (20) second penalty will be assessed.
- c. Two (2) wheels off will not incur an immediate penalty. However, repeated driving of this type is cause for a black flag.
- d. Penalties will not be assessed for accident avoidance or other reasons deemed sufficient by the track officials.

D7.4.3 Missed Slalom

Missing one or more gates of a given slalom will be counted as one "off-course" per occurrence. Each occurrence will incur a twenty (20) second penalty.

D7.5 Stalled & Disabled Vehicles

D7.5.1 If a car stalls and cannot restart without external assistance, the car will be deemed disabled.

D7.5.2 Disabled cars are scored DNF for that attempt.

D7.5.3 Disabled cars will be cleared from the track by the track workers. At the direction of the track officials team members may be instructed to retrieve the vehicle. Vehicle recovery may only be done under the control of the track officials.

D7.6 Corrected Elapsed Time

D7.6.1 The elapsed time plus any penalties from that specific run will be used as the corrected elapsed time.

D7.6.2 Cars that are unable to complete the course with an average speed of 80% of the fastest car will not be awarded “performance” points. This means that any autocross time in excess of 125% of the fastest time will receive no “performance” points.

D7.7 Best Run Scored

The time required to complete each run will be recorded and the team’s best corrected elapsed time will be used to determine the score.

D7.8 Autocross Scoring Formula

D7.8.1 The following equation is used to determine the autocross score:

$$\text{AUTOCROSS SCORE} = 142.5 \times \frac{\left(\frac{T_{\max}}{T_{\text{your}}}\right) - 1}{\left(\frac{T_{\max}}{T_{\min}}\right) - 1} + 7.5$$

Where:

Tmin is the lowest corrected elapsed time recorded for any competitor in either heat

Tmax is 125% of Tmin

Tyour is the lowest corrected elapsed time in either heat for the team being scored.

D7.8.2 In the equation above, the first term on the right hand side represents “performance” points, while the second term, or “completion” points represents the minimum score for having successfully completed the event.

- D7.8.3 Negative “performance” points will not be given. However, 7.5 points will be given for a car that completes a run, even if it exceeds 125% of the fastest time (T_{min})

ARTICLE 8: ENDURANCE AND FUEL ECONOMY

- D8.1** At Formula SAE competitions in North America the Endurance & Fuel Economy event will consist of a single heat. For competitions outside North America please check the event website.

- D8.2 Driver Eligibility** – The Endurance and Fuel Economy are separate events even though they are run simultaneously. Therefore anyone driving in a heat of Endurance and Fuel Economy uses two (2) driving eligibilities. (See Article D.4 “Driver Limitations”)

D8.3 Right to Change Procedure

This Article D.8, contains the general guidelines for conducting the Endurance and Fuel Economy event, however, the organizers reserve the right to establish procedures specific to the conduct of the event at the site. All such procedures will be made known to the teams through email or the specific FSAE competition news page website.

D8.4 Endurance Objective—300 points

The Endurance Event is designed to evaluate the overall performance of the car and to test the car’s durability and reliability.

D8.5 Fuel Economy—100 points

The car’s fuel economy will be measured in conjunction with the Endurance Event. The fuel economy under competition conditions is important in most vehicle competitions and also shows how well the car has been tuned for the competition. This is a compromise event because the fuel economy score and endurance score will be calculated from the same heat. No refueling will be allowed during an endurance heat.

D8.6 Endurance Course Specifications & Speeds

- D8.6.1 Course speeds can be estimated by the following standard course specifications. Average speed should be 48 km/hr (29.8 mph) to 57 km/hr (35.4 mph) with top speeds of approximately 105 km/hr (65.2 mph).

- D8.6.2 The standard specifications for the FSAE Endurance Course are:

Straights: No longer than 77.0 m (252.6 feet) with hairpins at both ends (or) no longer than 61.0 m (200.1 feet) with wide turns on the ends. There will be passing zones at several locations.

Constant Turns: 30.0 m (98.4 feet) to 54.0 m (177.2 feet) diameter.

Hairpin Turns: Minimum of 9.0 m (29.5 feet) outside diameter (of the turn).

Slaloms: Cones in a straight line with 9.0 m (29.5 feet) to 15.0 m (49.2 feet) spacing.

Miscellaneous: Chicanes, multiple turns, decreasing radius turns, etc. The standard minimum track width is 4.5 m (14.76 feet).

D8.6.3 The organizers reserve the right to deviate from the standard specifications when they determine it is appropriate given the characteristics of a particular competition site.

D8.7 Endurance General Procedure

D8.7.1 The event will be run as a single heat approximately 22 km (13.66 miles) long.

D8.7.2 Teams are not allowed to work on their vehicles during the heat.

D8.7.3 A driver change must be made during a three (3) minute period at the midpoint of the heat.

D8.7.4 Wheel-to-wheel racing is prohibited.

D8.7.5 Passing another vehicle may only be done in an established passing zone or under control of a course marshal.

D8.7.6 Elapsed time will begin when Driver A enters the course and crosses the timing line.

D8.8 Endurance Run Order

D8.8.1 The run order for endurance will be based primarily on the finish order for the autocross event with the fastest team first followed by the second fastest etc. For teams without an autocross score, the finish order for the acceleration event may be substituted. For teams without a score in either autocross or acceleration, the finish order for skid pad may be substituted. Teams without a score in the event used to determine the run order may run at the end of the heat.

D8.8.2 Based on the results of all dynamic events, and considering the operating conditions under which they were run, the endurance event captain may, at his sole discretion, move teams to different positions within the starting order.

D8.8.3 Teams are required to keep track of the run order and have their cars fueled, in line and prepared to start when their turn to run arrives.

D8.8.4 Teams that are not ready-to-run when their turn arrives will be penalized two (2) minutes and permitted to run at the end of the heat (time permitting) or at the discretion of the event captain.

D8.9 Endurance Fuel Fill

Before entering the event each vehicle's fuel tank must be filled to the fuel level line (see Rule B.9.6.6, "Fuel Level Line") at the fueling station. During fueling and post-event refueling, once filled to the scribe line, no shaking or tilting of the tank or fuel system (incl. entire vehicle) is allowed.

D8.10 Endurance Vehicle Starting/ Restarting

D8.10.1 The vehicle must be capable of starting / restarting without external assistance at all times once the vehicle has begun the heat.

D8.10.2 If a vehicle stalls out on the track, it will be allowed one (1) lap by the car that is following it (approximately one (1) minute) to restart.

D8.10.3 If a vehicle has a restart problem at the end of Driver Change, it will be allowed a further two (2) minutes to restart the engine.

D8.10.4 If restarts are not accomplished within the above times, the car will be deemed disabled and scored DNF for the heat.

D8.11 Endurance Driver Change Procedure

- D8.11.1 Three (3) minutes are allowed for the team to change drivers.
- D8.11.2 Only three (3) team members, including the driver or drivers, will be allowed in the driver change area, and only the tools necessary adjust the car to accommodate the second driver and/or change tires will be carried into this area (no tool chests etc.). Extra people entering the driver change area will result in a twenty point (20 pt) penalty to the final endurance score for each extra person entering the area.
- D.8.11.3 Other than changes to accommodate the second driver or covered by D.3.8.2 “Tire Changing”, the team is not permitted to perform any work on the car at Driver Change.
- D8.11.4 Driver A will drive for 11 km (6.83 miles), and then be signaled into the driver change area.
- D8.11.5 Driver A will exit the vehicle and any necessary adjustments will be made to the vehicle to fit Driver B (seat cushions, head restraint, pedal position, etc.). Driver B will then be secured in the vehicle.
- D8.11.6 Driver B will drive for 11 km (6.83 miles) and elapsed time will stop when the car completes the total 22 km (13.66 miles) distance.
- D8.11.7 Driver B will proceed directly to the fueling station. The tank will be refilled to fill mark and the amount will be recorded.
- D8.11.8 The driver change area will be placed such that the timing system will see the driver change as an extra long lap. Unless this driver change takes longer than three minutes, this extra long lap will not count. If the driver change takes longer than three minutes, the extra time will be counted into the final time.

D8.12 Entering the Track

- D8.12.1 Cars will be allowed to enter the track based upon the level of traffic on the course.
- D8.12.2 The number of vehicles simultaneously on the course depends on the track length and design as well as the operating conditions. In dry conditions, there are typically 5 to 7 vehicles allowed per kilometer of track. This includes cars in the driver change area.
- D8.12.3 Because repairs are not allowed during the heat, and there will be no refueling during the heat, there will not be a restart queue of any kind.

D8.13 Breakdowns & Stalls

- D8.13.1 If a vehicle breaks down it will be removed from the course and will not be allowed to re-enter the course.
- D8.13.2 If a vehicle stalls, or ingests a cone, etc., it will be allowed to restart (See D.8.10 “Endurance Vehicle Starting/Restarting”) and re-enter the course where it went off, but no work may be performed on the vehicle.
- D8.13.3 If a car stalls and cannot be restarted without external assistance, the track workers will push the car clear of the track. At the discretion of event officials, two (2) team members may retrieve the car under direction of the track workers.

Comment – Teams are reminded that although course crews exercise due care, the organizers are not responsible for any damage that may occur when moving a disabled vehicle. Please consider the comment to Rule B6.6 “Jacking Point”.

D8.14 Endurance Minimum Speed Requirement

- D8.14.1 If a car is unable to maintain lap times within 145% of the fastest lap time for the course, then it must exit immediately.
- D8.14.2 Disqualification for failure to maintain the minimum speed will be made at the discretion of the Chief Marshall/Director of Operations.

D8.15 Post Event Refueling

Vehicles must power down after leaving the course and be pushed to the fueling area.

Fuel pumps will be turned on and fuel valves will be opened to insure complete refueling.

D8.16 Endurance Lap Timing

Each lap of the endurance event will be individually timed either by electronic means, or by hand. The time for an individual heat will be determined by subtracting the extra long lap for the driver change, and the time taken for any stops under a mechanical black flag, from the total time and adding any penalty points.

D8.17 Endurance Penalties

- D8.17.1 Penalties will not be assessed for accident avoidance or other reason deemed sufficient by the track official.
- D8.17.2 The penalties in effect during the Endurance Event are listed below.
- D8.17.3 Cones
Cone down or out (DOO) - two (2) seconds per cone. This includes cones before the start line and after the finish line.
- D8.17.4 *Off Course (OC)*
- a. *An “off course” occurs when the vehicle has all four (4) wheels outside the course boundary as indicated by (a) cones, (b) edge marking or (c) the edge of the paved surface. Where more than one boundary indicator is used on the same course, at any given point the narrowest track will be used when determining off course penalties.*
 - b. *When an OC occurs, the driver must reenter the track at or prior to the point of exit or a twenty (20) second penalty will be assessed.*
 - c. *Two (2) wheels off will not incur an immediate penalty. However, repeated driving of this type is cause for a black flag. .*
- D8.17.5 Missed Slalom
Missing one or more gates of a given slalom will incur a twenty (20) second penalty.
- D8.17.6 Penalties for Moving Violations
The following are penalties and assessed times or disqualifications for moving violations:
- a. Failure to obey a flag: 1 minute
 - b. Over Driving (After a closed black flag): 1 Minute
 - c. Vehicle to Vehicle contact: 2 Minutes up to disqualification depending on the nature of the incident.

D8.17.7 Out of Order
Running out of order – two (2) minute penalty.

D8.17.8 Mechanical Problem
No time penalty. The time taken for mechanical inspection under a “mechanical black flag” is considered officials’ time and is not included in the teams’ total time. However, if the inspection reveals a mechanical integrity problem the vehicle may be disqualified under Rule D.1.1 “Vehicle Integrity and Disqualification”.

D8.17.9 Reckless or Aggressive Driving
Any reckless or aggressive driving behavior (such as forcing another car off the track, refusal to allow passing, or close driving that would cause the likelihood of car contact) will result in a black flag for that driver. When a driver receives a black flag signal, he must proceed to the penalty box to listen to a reprimand for his driving behavior. The amount of time spent in the penalty box will vary from one (1) to four (4) minutes depending upon the severity of the offense.

If it is impossible to impose a penalty by a stop under a black flag, e.g. not enough laps left, the event officials may add an appropriate time penalty to the team’s elapsed time.

D8.17.10 Vehicle Control Issues
The Chief Marshall/Director of Operations may disqualify a vehicle if, for any reason including driver inexperience and mechanical problems, it is too slow or being driven in a manner that, in the sole opinion of the event officials demonstrates an inability to properly control the car. Disqualification for a vehicle control issue is scored as DNF.

D8.18 Endurance Scoring

D8.18.1 The score for the Endurance Event is the sum of the Endurance Time Score and the Endurance Finish Score.

D8.18.2 The Endurance Time Score is based on the team's time for the event, including penalties, compared to the fastest team.

D8.18.3 A car will also receive an Endurance Finish Score of fifty (50) points if the team's time for the event, including penalties, is less than or equal to the maximum allotted time.

D8.19 Endurance Scoring Formula

D8.19.1 The times for the endurance event will be based upon the sum of the times of each driver in the heat plus penalties.

D8.19.2 The following equation is used to determine the time scores for the event:
If **T_{your}** is < or = to **T_{max}**:

$$\text{ENDURANCE SCORE} = 250 \times \frac{(\text{T}_{\text{max}}/\text{T}_{\text{your}}) - 1}{(\text{T}_{\text{max}}/\text{T}_{\text{min}}) - 1} + 50$$

If **T_{your}** > **T_{max}**: ENDURANCE SCORE = 0 (ZERO)

T_{min} will be the lowest corrected time of the fastest team of the event.

T_{your} will be the combined corrected times of both of your team’s drivers in the heat.

Tmax will be 1.45 times **Tmin**.

If *ENDURANCE SCORE* < **LapsComp**, then *ENDURANCE SCORE* = **LapsComp**

LapsComp is the number of full laps completed by the team.

D8.19.3 If, in the opinion of the officials, course conditions change significantly during the running of the event then they may, at their sole discretion, set **Tmax** to a higher value.

D8.20 Fuel Economy

The Fuel Economy score is based on the average liters per kilometer fuel economy obtained during the endurance heat.

Teams are advised that the fuel economy score is based only on the distance cars run on the course during the endurance event. Although the starting line, exit line and the driver change zone increase the actual distance a car must drive during the event, those distances are not factored into the fuel economy calculations. Additionally fuel consumption adjustments will not be made for engine running in the entry/exit lines, during driver change, in the penalty box or for any on-course incidents.

Note: Teams are reminded to refer to Rule B9.7.1 which covers fuel tank filling requirements.

D8.21 E85 Correction Factor

The volume of E85 fuel will be divided by a 1.40 correction factor to determine the gasoline equivalent volume. This correction factor is equal to the ratio of energy (lower heating value) per unit volume of gasoline to E85.

D8.22 Fuel Economy Scoring Formula

D8.22.1 If **V_{your}** is less than **V_{max}** then the following equation will be used to determine the fuel economy score:

$$\text{FUEL ECONOMY SCORE} = 100 \times \left(\frac{(V_{\text{max}} - V_{\text{your}})}{(V_{\text{max}} - V_{\text{min}})} \right)$$

If **V_{your}** is greater than **V_{max}** then the following equation will be used to determine a negative fuel economy score:

$$\text{FUEL ECONOMY SCORE} = -100 \times \left(\frac{(V_{\text{your}}/V_{\text{max}}) - 1}{0.33} \right)^{1.5}$$

Where:

V_{max} is the volume of fuel that produces a fuel consumption of 26 liters/ 100 km. Note - For an Endurance Event distance of exactly 22 km, **V_{max}** is 5.72 liters (1.51 US gallons)."

V_{min} is the smallest volume of fuel used by any competitor

V_{your} is the volume of fuel used by the team being scored

D8.22.2 Vehicles using a fuel volume which exceeds **V_{max}** by 33% will score negative one hundred (-100) points.

- D8.22.3 Vehicles whose corrected time exceeds 1.45 times the corrected time of the fastest team, will receive zero (0) points for fuel economy.
- D8.22.4 For shortened courses, V_{min} will be the low value per heat.
- D8.22.5 Fuel economy scores can range from negative one hundred (-100) to positive one hundred (100) points.
- D8.22.6 The minimum combined score for the endurance and fuel economy event will be zero (0) points.

D8.23 Endurance and Fuel Economy Scoring with Two Heats

If the Endurance and Fuel Economy is run with two (2) heats, the following procedure will apply:

- a. **T_{min}** will be the lowest corrected time of the fastest team of the event in either heat.
- b. **V_{min}** will be the smallest volume of fuel used by any team in either heat; provided that team's Corrected Time from that heat does not exceed **T_{max}**.
Note: **T_{min}** and **V_{min}** do not have to be from the same heat.
- c. The score for a team will be taken from the heat that gives the higher total Endurance & Fuel Economy Score for that team, i.e. **T_{your}** and **V_{your}** will be from the same heat.

D8.24 Post Event Engine Check

The organizer reserves the right to impound any vehicle immediately after the event to check engine displacement (method to be determined by the organizer) and restrictor size.

D8.25 Endurance Event – Driving

- D8.25.1 During Endurance when multiple cars are running on the course it is paramount that the drivers strictly follow all of the rules and driving requirements.
- D8.25.2 Aggressive driving, failing to obey signals, not yielding for passing, etc will result in a black flag and a discussion in the penalty box with course officials. The amount of time spent in the penalty box is at the discretion of the officials and is included in the run time. Penalty box time serves as a reprimand as well as informing the driver of what he/she did wrong. Drivers should be aware that contact between open wheel vehicles is especially dangerous because tires touching can throw one car into the air.

Endurance is a timed event in which drivers compete only against the clock not against other cars. Aggressive driving is unnecessary.

D8.26 Endurance Event – Passing

- D8.26.1 Passing during Endurance may only be done in the designated passing zones and under the control of the track officials.
- D8.26.2 Passing zones have two parallel lanes – a slow lane for the cars that are being passed and a fast lane for the cars that are making a pass. On approaching a passing zone a slower leading car will be blue flagged and must shift into the slow lane and decelerate. The following faster car will continue in the fast lane and make the pass. The car that had been passed may reenter traffic only under the control of the passing zone exit flagman.
- D8.26.3 Passing, i.e. slow, lanes may be either to the left or right of the fast lane depending on the design of the specific course.

D8.26.4 These passing rules do not apply to cars that are passing disabled cars on the course or cars that have spun out and are not moving. When passing a disabled or off-track car it is critical to slow down, drive cautiously and be aware of all the vehicles and track workers in the area.

D8.26.5 Under normal driving conditions when not being passed all cars use the fast lane.

D8.27 Endurance Event – Driver’s Course Walk

The endurance course will be available for walk by drivers prior to the event. All endurance drivers are required to walk the course before the event starts.

ARTICLE 9: FLAGS

D9.1 Flag Effect

Flag signals are commands that must be obeyed immediately and without question.

D9.2 Flag Types

There are two kinds of flags for the competition: Command flags and Informational flags.

D9.2.1 Command flags are just that, flags that send a message to the competitor that the competitor must obey without question.

D9.2.2 Informational flags, on the other hand, require no action from the driver, but should be used as added information to help him or her to maximize performance.

D9.3 Command Flags

The following is a brief description of the flags used at the competitions in North America and what each flag means.

Note: Not all of these flags are used at all competitions and some alternate designs are occasionally displayed. Any variations from this list will be explained at the drivers meetings.

D9.3.1 **BLACK FLAG** - Pull into the penalty box for discussion with the Chief Marshall/Director of Operations or other official concerning an incident. A time penalty may be assessed for such incident.

D9.3.2 **BLACK FLAG - With Orange Dot – “Mechanical Black Flag”** - Pull into the penalty box for a mechanical inspection of your car, something has been observed that needs closer inspection.

D9.3.3 **BLUE FLAG** - Pull into the designated passing zone to be passed by a faster competitor. Obey the corner workers hand signals at the end of the passing zone to merge into competition.

D9.3.4 **CHECKER FLAG** - Your session has been completed. Exit the course at the first opportunity.

D9.3.5 **GREEN FLAG** - Your session has started, enter the course under direction of the starter. (NOTE: If you stall the vehicle, please restart and await another green flag as the opening in traffic may have closed.)

D9.3.6 **RED FLAG** - Come to an immediate safe controlled stop on the course. Pull to the side of the course as much as possible to keep the course open. Follow corner worker directions.

D9.3.7 **YELLOW FLAG (Stationary)** - Danger, **SLOW DOWN**, be prepared to take evasive action, something has happened beyond the flag station. **NO PASSING** unless directed by the corner workers.

D9.3.8 **YELLOW FLAG (Waved)** - Great Danger, SLOW DOWN, evasive action is most likely required, BE PREPARED TO STOP, something has happened beyond the flag station, NO PASSING unless directed by the corner workers.

D9.4 Informational Flags

D9.4.1 **RED AND YELLOW STRIPED FLAG** - Something is on the racing surface that should not be there. Be prepared for evasive maneuvers to avoid the situation. (Corner workers may be able to point out what and where it is located, but do not expect it.)

D9.4.2 **WHITE FLAG** - There is a slow moving vehicle on the course that is much slower than you are. Be prepared to approach it at a cautious rate.

ARTICLE 10: RULES OF CONDUCT

D10.1 Competition Objective – A Reminder

The Formula SAE® event is a design engineering competition that requires performance demonstration of vehicles and is NOT a race. Engineering ethics will apply. It is recognized that hundreds of hours of labor have gone into fielding an entry into Formula SAE. It is also recognized that this event is an “engineering educational experience” but that it often times becomes confused with a high stakes race. In the heat of competition, emotions peak and disputes arise. Our officials are trained volunteers and maximum human effort will be made to settle problems in an equitable, professional manner.

D10.2 Unsportsmanlike Conduct

In the event of unsportsmanlike conduct, the team will receive a warning from an official. A second violation will result in expulsion of the team from the competition.

D10.3 Official Instructions

Failure of a team member to follow an instruction or command directed specifically to that team or team member will result in a twenty five (25) point penalty.

Note: This penalty can be individually applied to all members of a team.

D10.4 Arguments with Officials

Argument with, or disobedience to, any official may result in the team being eliminated from the competition. All members of the team may be immediately escorted from the grounds.

D10.5 Alcohol and Illegal Material

D10.5.1 Alcohol, illegal drugs, weapons or other illegal material are prohibited on the event site during the competition. This rule will be in effect during the entire competition.

D10.5.2 Any violation of this rule by a team member will cause the expulsion of the entire team. This applies to both team members and faculty advisors.

D10.5.3 Any use of drugs, or the use of alcohol by an underage individual, will be reported to the local authorities.

D10.6 Parties

In the interest of responsible citizenship it is expected that any disruptive parties, either on or off-site, will be prevented by the Faculty Advisor.

D10.7 Trash Clean-up

D10.7.1 Cleanup of trash and debris is the responsibility of the teams. The team's work area should be kept uncluttered. At the end of the day, each team must clean all debris from their area and help with maintaining a clean paddock.

D10.7.2 Teams are required to remove all of their material and trash when leaving the site at the end of the competition. Teams that abandon furniture, or that leave a paddock that requires special cleaning, will be billed for removal and/or cleanup costs.

ARTICLE 11: GENERAL RULES

D11.1 Dynamometer Usage

If a dynamometer is available, it may be used by any competing team. Vehicles to be dynamometer tested must have passed all parts of technical inspection.

Fuel, ignition and drivetrain tuning will be permitted while testing on the dynamometer.

D11.2 Problem Resolution

Any problems that arise during the competition will be resolved through the Operations Center and the decision will be final.

D11.3 Forfeit for Non-Appearance

D11.3.1 It is the responsibility of teams to be in the right place at the right time.

D11.3.2 If a team is not present and ready to compete at the scheduled time they forfeit their attempt at that event.

D11.3.3 There are no make-ups for missed appearances.

D11.4 Drivers Meetings – Attendance Required

All drivers for an event are required to attend the pre-event drivers meeting(s). The driver for an event will be disqualified if he/she does not attend the driver meeting for the event.

D11.5 Personal Vehicles

Personal cars and trailers must be parked in designated areas only. Only FSAE competition vehicles will be allowed in the track areas.

D11.6 Motorcycles, Bicycles, Rollerblades, etc.—Prohibited

The use of motorcycles, quads, bicycles, scooters, skateboards, rollerblades or similar person-carrying devices by team members and spectators in any part of the competition area, including the paddocks, is prohibited.

D11.7 Self-propelled Pit Carts, Tool Boxes, etc. - Prohibited

The use of self-propelled pit carts, tool boxes, tire carriers or similar motorized devices in any part of the competition site, including the paddocks, is prohibited.

D11.8 Starting

D11.8.1 Push starts are prohibited.

D11.8.2 The use of auxiliary batteries is prohibited once a car has moved to the starting line of any event.

D11.9 Footwear

Everyone in a “dynamic” area (an area where cars can be moving under their own power) must wear closed-toed shoes.

ARTICLE 12: PROTESTS

D12.1 Protests can be filed in relation to both static and dynamic events, therefore the protest policies and procedures have been relocated from Part C “Dynamic Event Regulations” to Part A “Administrative Regulations” and are now Part A, Article 9 “Protests”. Those rules are otherwise unchanged.

ARTICLE 13: PIT RULES

D13.1 Vehicle Movement

D13.1.1 Vehicles may not move under their own power anywhere but on the practice or competition tracks, or as otherwise directed by the organizers.

D13.1.2 Off track vehicles must be pushed at a normal walking pace by means of a “Push Bar” (Rule B17.5) with all four (4) wheels on the ground, a team member sitting in the cockpit to steer and brake and with another team member walking beside the car.

D13.1.3 Cars with wings are required to have two team members walking on either side of the vehicle whenever the vehicle is being pushed.

D13.1.4 During performance events when the excitement is high, it is particularly important that the car be moved at a slow pace in the pits.

D13.1.5 The walking rule will be enforced and a point penalty of twenty five (25) points will be assessed for each violation.

D13.2 Smoking – Prohibited

Smoking is prohibited in all competition areas.

D13.3 Fueling and Refueling

Officials must conduct all fueling and refueling.

D13.4 Engine and Vehicle Running Requirements

Engines may be run in the paddock provided the car has passed Parts 1 and 2 of Technical Inspection (C.2.7) and the following conditions are satisfied:

- a. The car is on sturdy and adequate stand, and
- b. The drive wheels are at least 10.2 cm (4 in) off the ground, or the driver wheels have been removed.

ARTICLE 14: DRIVING RULES

D14.1 Driving Under Power

D14.1.1 Cars may only be driven under power (a) when running in an event, (b) on the practice track and (c) during brake test or (d) during any powered vehicle movement specified and authorized by the organizers.

D14.1.2 For all other movements cars must be pushed at a normal walking pace using a push bar (Rule B17.5).

D14.1.3 Driving a vehicle outside of scheduled events or scheduled practice will result in a two hundred (200) point penalty for the first violation and disqualification for a second violation.

D14.2 Driving Off-site

Driving off-site is absolutely prohibited. Teams found to have driven their vehicle at an off-site location during the period of the competition will be expelled from the competition and receive a final score of zero (0).

D14.3 Practice Track

D14.3.1 A practice track for testing and tuning cars may be available at the discretion of the organizers. The practice area will be controlled and may only be used during the scheduled practice times.

D14.3.2 Practice or testing at any location other than the practice track is absolutely forbidden.

D14.3.3 Cars using the practice track must have all parts of the technical inspection sticker.

D14.4 Situational Awareness

Drivers must maintain a high state of situational awareness at all times and be ready to respond to the track conditions and incidents. Flag signals and hand signals from course marshals and officials must be immediately obeyed.

ARTICLE 15: DEFINITIONS

D15.1 DOO - A cone is “Down or Out”—if the cone has been knocked over or the entire base of the cone lies outside the box marked around the cone in its undisturbed position.

D15.2 DNF- Did Not Finish

D15.3 Gate - The path between two cones through which the car must pass. Two cones, one on each side of the course define a gate: Two sequential cones in a slalom define a gate.

D15.3.1 Entry Gate -The path marked by cones which establishes the required path the vehicle must take to enter the course.

D15.3.2 Exit Gate - The path marked by cones which establishes the required path the vehicle must take to exit the course.

D15.4 Staging Area - An area prior to the entry to an event for the purpose of gathering those cars that are about to start.

D15.5 OC - A car is Off Course if it does not pass through a gate in the required direction.